



DUC *Helices* Propellers

Instruction manual Variable pitch propellers in flight **FLASHBLACK/-2** **SWIRLBLACK-3**



Aérodrome de Villefranche Tarare (LFHV)
289 Avenue Odette & Edouard DURAND
69620 FRONTENAS - FRANCE
Phone: + 33 (0)4 74 72 12 69 - Fax: +33 (0)4 74 72 10 01
E-mail: contact@DUC-helices.com - www.DUC-helices.com

ISO 9001
BUREAU VERITAS
Certification



ISO 9001:2015 Certified Company
for its Quality System Management

Revision update

Date	Index	Object of modification
23/07/2014	A	Creation
20/07/2017	F	Add SWIRLBLACK-3 & TBO update
11/12/2017	F	Minor correction
10/04/2018	F	English language correction
04/12/2018	G	Minor change in page 42
24/02/2021	H	Adaptation for ASTM F2506-13



Identification

This instruction manual is to be maintained throughout the life of the propeller.
He may have to evolve. The owner must check with the DUC Hélices Company
the latest version being valid applicable to the propeller.

Contents

1. Variable pitch FLASHBLACK/-2 & SWIRLBLACK-3 prop.	6
1.1. Description	6
1.2. Characteristics.....	6
1.3. FLASHBLACK/-2 & SWIRLBLACK-3 propellers version	7
1.4. Shielding leading edge in Inconel	7
1.5. Accessories	7
1.6. Sales reference	8
2. Applications.....	8
3. Installation and using precautions	9
4. Technical data of FLASHBLACK/-2 & SWIRLBLACK-3 propeller.....	9
4.1. Mounting.....	10
4.2. Hardware.....	11
4.3. Exploded view for propeller	12
4.4. Control receiver system	13
4.5. Pitch controller.....	14
4.6. Visual indicator of pitch	18
5. Mounting instruction of the FLASHBLACK/-2 propeller	19
5.1. Package contents.....	19
5.2. Operator & List of required tools	21
5.3. The assembly of the propeller on table	21
5.4. Installation on the aircraft	24
5.5. Installation of command receiver system	25
5.6. Installation of the hydraulic command and visual indicator.....	28
5.7. Visual indicator of pitch	31
5.8. Execution of electrical wiring.....	31
5.9. Installation of the hydraulic system	32
5.10. Finalization of propeller mounting	39
6. Setting the small pitch stop and static tests on ground of the propeller	40
7. First taxi tests and then fly tests of the propeller	44
8. Management of the failure of the variable pitch system	44
9. Installation without spinner or with spinner other than DUC.....	44
10. Potential use & Propeller maintenance.....	46
10.1. The potential use of the propeller: Unlimited	46
10.2. Propeller maintenance schedule.....	46
10.3. Regular maintenance (by the user).....	46
10.4. General maintenance (by the user or an aeronautics workshop)	47
10.5. Complete maintenance (by DUC Propellers Company)	47
11. General terms sale.....	48

11.1.	Ordering procedure	48
11.2.	Delivery	48
11.3.	Price	48
11.4.	Right of withdrawal	48
11.5.	Warranties	48
11.6.	Privacy Policy	48
11.7.	Litigation	48
12.	Annexes	49
12.1.	The dimension of the ROTAX 912/912S/914 propeller-shaft	49
12.2.	Airfoil	49
12.3.	Moment of inertia of the propeller	50
12.4.	Engine performance data's	50
12.5.	Operating limitation of the FLASH propeller	51
12.6.	Identification marking of the propeller	51
12.7.	Calculation of the centrifugal force of the FLASH Inconel blade	51
12.8.	Centrifugal force test	51
12.9.	Breaking test of the 2-blade Inconel FLASH propeller	51
12.10.	Declaration of conformance of the FLASH propellers.....	52

1. Variable pitch **FLASHBLACK/-2** & **SWIRLBLACK-3** prop.

1.1. Description

The **FLASHBLACK/-2** & **SWIRLBLACK-3** are the new generation innovative variable pitch propeller which have the best performances for all flight's stages. These are a blend of carbon/titanium blades and carbon/aluminum hub which are manufactured in accordance with the DUC Propellers technologies. Then, the **FLASHBLACK/-2** & **SWIRLBLACK-3** propellers are the lighter variable pitch propellers ever designed.

The aerodynamic shape of blades uses the innovative design of the **FLASH** & **SWIRL-3 tractor** propeller, and the **FLASH-2** pusher propeller.

These propellers allow to have **high efficiency** throughout the flight envelope i.e.:

- **High efficiency during takeoff and high climb rate**
- **High efficiency during cruise and maximum speed**
- **High user comfort**

Equipped with screws in grade 5 titanium, this technology and manufacturing level and requirement degree have never been to this advancement.

This carbon's system hub for variable pitch propeller allows a wide range of angle variation but keeps safety thanks to the mechanical safety stop.

The angle pitch is adjusted manually or automatically with constant speed box. Also, a visual indicator of the pitch is provided with the propeller.

The power of the variable pitch system is hydraulic and the control can be hydraulic or electric.

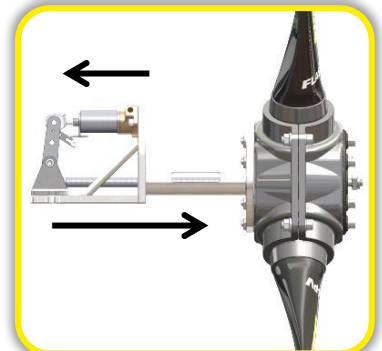

1.2. Characteristics

FLASHBLACK & SWIRLBLACK-3 Tractor

- Tractor for Rotax engine with hollow shaft (Rotax 912/912S/912iS/914)
- Two-blade or Three-blade
- **Prop & pack weights:**
FLASHBLACK 4.9kg/2-blade & 6.5kg/3-blade
SWIRLBLACK-3 6.2kg/3-blade
Pack **BASE**: +1 kg | Pack **CST SPEED**: +1.75 kg
- The range of adjustable angle (Max amplitude.: 23°)
- Diameters Ø1520 to Ø1900mm (Ø60" to Ø75")
- Shielded leading edge in Inconel®
- Carbon/aluminum composite hub for variable pitch propeller (Mounting propeller shaft spacing Ø101.6mm)

FLASHBLACK-2 Pusher

- Pusher for Rotax engine with hollow shaft (Rotax 912/912S/912iS/914)
- Three-blade
- **Propeller weight: 6.8kg in Three-blade**
BASE pack: 7.8 in 3-blade
CST SPEED pack: 8.24kg in 3-blade
- The range of adjustable angle (Max amplitude.: 23°)
- Diameters Ø1520 to Ø1900mm (Ø60" to Ø75")
- Shielded leading edge in Inconel®
- Carbon/aluminum composite hub for variable pitch propeller (Mounting propeller shaft spacing Ø101.6mm)

1.3. FLASHBLACK/-2 & SWIRLBLACK-3 propellers version

2 propellers versions are proposed to control the pitch with different commands:

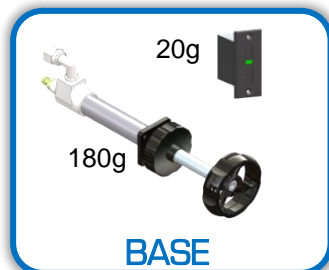

BASE

Included:

- Visual pitch indicator
- Hydraulic control wheel



CONSTANT SPEED

BASE + included: Hydraulic pump

- Constant Speed box replace the hydraulic wheel

1.4. Shielding leading edge in Inconel

The leading edge of the FLASHBLACK/-2 & SWIRLBLACK-3 blades is composed of a metallic shielding in Inconel®. This material is a superalloy including mainly nickel, with a very high hardness of the surface.

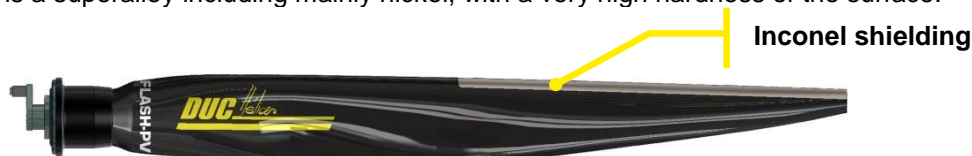

1.5. Accessories

- **Aluminum mounting spacer (Direct mounting on P.C.D Ø101.6mm/Ø4")**
Moves the plane of the propeller to adjust the position in accordance with the engine hood
- **Spinner available in diameter Ø250mm (Ø9.8"), Ø260 (Ø10.2"), Ø300 (Ø11.8") & Ø340mm (Ø14.4")**
- **Adjusting tool for the setting of the pitch angle of the blades**
- **Neoprene cover protection of the blade**
- **Cleaning treatment for composite propellers**
Save money! A clean propeller is more efficient and decreases the fuel consumption.



1.6. Sales reference

Version	Designation	Reference	Part number	Weight (kg)
BASE	Two-blade Inconel FLASHBLACK right propeller with pitch indicator & hydraulic wheel control	01-26-001	H-FSH_2-D-PV_I	5.90
	Three-blade Inconel FLASHBLACK right propeller with pitch indicator & hydraulic wheel control	01-27-001	H-FSH_3-D-PV_I	7.50
	Three-blade Inconel SWIRLBLACK-3 right prop. with pitch indicator & hydraulic wheel control	01-44-001	H-SW3_3-D-PV_I	7.20
	Three-blade Inconel FLASHBLACK-2 left propeller with pitch indicator & hydraulic wheel control	01-35-001	H-FSH2_3-G-PV_I	7.80
CONSTANT SPEED	Hydraulic pump & Constant Speed box	01-69-003	-	+0.74

Note:

Specify the flight regulation aircraft (E.g.: **Ultra-light, LSA...**) and diameter when ordering (E.g.: ref. 01-21-001/**1730**). For more information about the propeller marking, see section 12.6.

2. Applications

The DUC Propellers Company has an **unlimited** flight potential in normal operation. To keep the unlimited potential, DUC Propellers Company defined a TBO (Time Between Overhaul) for a propeller depending on its engine. Refer to section 10. **Potential use & Propeller maintenance** for more information.

Engine	Type	Gear box	Recommended propeller	Propeller diameter (inch)	Pitch angle amplitude (°)	TBO (hour)
3 AXIS TRACTOR						
ROTAX 912/912S/912iS/914	4 strokes	2.273 2.43	Two-blade Inconel FLASHBLACK , right	60'' to 75''	23°	1500h or 5 years
			Three-blade Inconel FLASHBLACK , right			
			Three-blade Inconel SWIRLBLACK-3 , right			
PUSHER						
ROTAX 912/912S/912iS/914	4 strokes	2.273 2.43	Three-blade Inconel FLASHBLACK-2 , Left	60'' to 75''	23°	1500h or 5 years
OTHERS APPLICATIONS						
For all other applications, thank you to contact the DUC Propellers Company to study the possibility of adapting the FLASHBLACK/-2 & SWIRLBLACK-3 propeller.						

* Ø 1900mm = 74.8»; Ø 1520mm = Ø 59.8"

Remark

The pitch angle's value are theoretical and combined with the engine. This setting should be adjusted according to the aircraft. Thus, dependent on the type of aircraft, a pitch angle range is defined. The magnitude of this range must not exceed the specified above (see section 7. **First taxi tests and then fly tests of the propeller**).

For proper use of the propeller, refer to section 10. **Potential use & Propeller maintenance**.

3. Installation and using precautions



RECOMMENDATION

As recommended by the BRP manufacturer of Rotax engine, it's strongly recommended to use variable pitch **FLASHBLACK/-2** & **SWIRLBLACK-3** propeller with an aircraft equipped with a vacuum indicator on engine intake manifold (**Pressure of the engine intake - PA**) to know the engine load. Refer to your engine manual or the section **12.3 Moment of inertia** of the propeller

Propeller Type					
FLASHBLACK		FLASHBLACK-2		SWIRLBLACK-3	
Diametre (mm)	Inertia (kg.cm ²)	Diametre (mm)	Inertia (kg.cm ²)	Diametre (mm)	Inertia (kg.cm ²)
1620	3811	1620	4192	1620	3630
1660	3954	1660	4349	1660	3765
1700	4104	1700	4514	1700	3908
1730	4208	1730	4629	1730	4008
1750	4280	1750	4708	1750	4076
1850	4643	1850	5107	1850	4422
1900	4823	1900	5306	1900	4594

Engine performance data's.

WARNING

Make sure the ignition circuit is turned off before starting any type of operation. Do not work the engine without a propeller, engine damage will (due to)?

IMPORTANT

- The propeller 's blades are part of a package. **DO NOT EXCHANGE IT** with other similar blades from the propeller. The propeller's blades are manufactured to their application. Their structure, weight, and balance are different from a propeller to another.

- The spinner is an important element for cooling the engine. The aircraft must not fly without a spinner. Fitting a different spinner will be an addendum to this manual approved by the DUC to confirm its compatibility with the mounting of the propeller.

- The propeller is delivered with the appropriate screws. **The change of the screws is contrary to our recommendations unless validated by manufacturers.**

WARRANTY CONDITIONS

The user is still flying under his full responsibility (see. **6. General terms of sale**).

4. Technical data of FLASHBLACK/-2 & SWIRLBLACK-3 propeller

4.1. Mounting

The **FLASHBLACK/-2** & **SWIRLBLACK-3** propeller is designed to be installed on the Rotax 912 engine propeller shaft. The propeller shaft is composed of:

- ✓ 6 bushes $\varnothing 13$ with spacing of $\varnothing 101.6\text{mm}$ (4").
- ✓ The hollow shaft which crossing the gear to permit the pitch command installation behind the gear.

Consult **12.1** to know the ROTAX 912/912S/912iS/914 propeller shaft dimensions.

For a different engine with a hollow shaft, a specific adaptation can be realized. Thanks to contact with DUC Propellers Company.

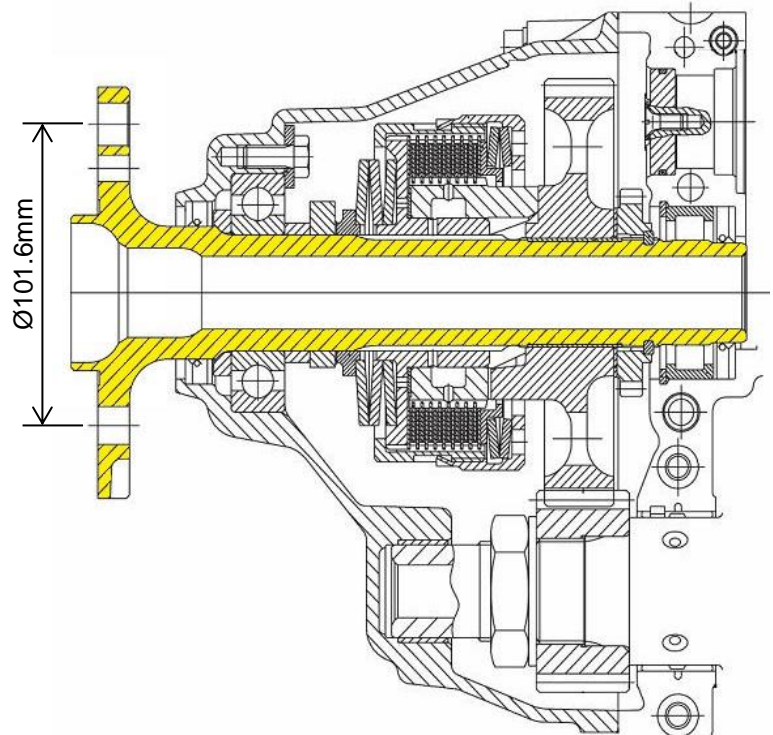

Here the carbon/aluminum hub dimensions of the propeller:

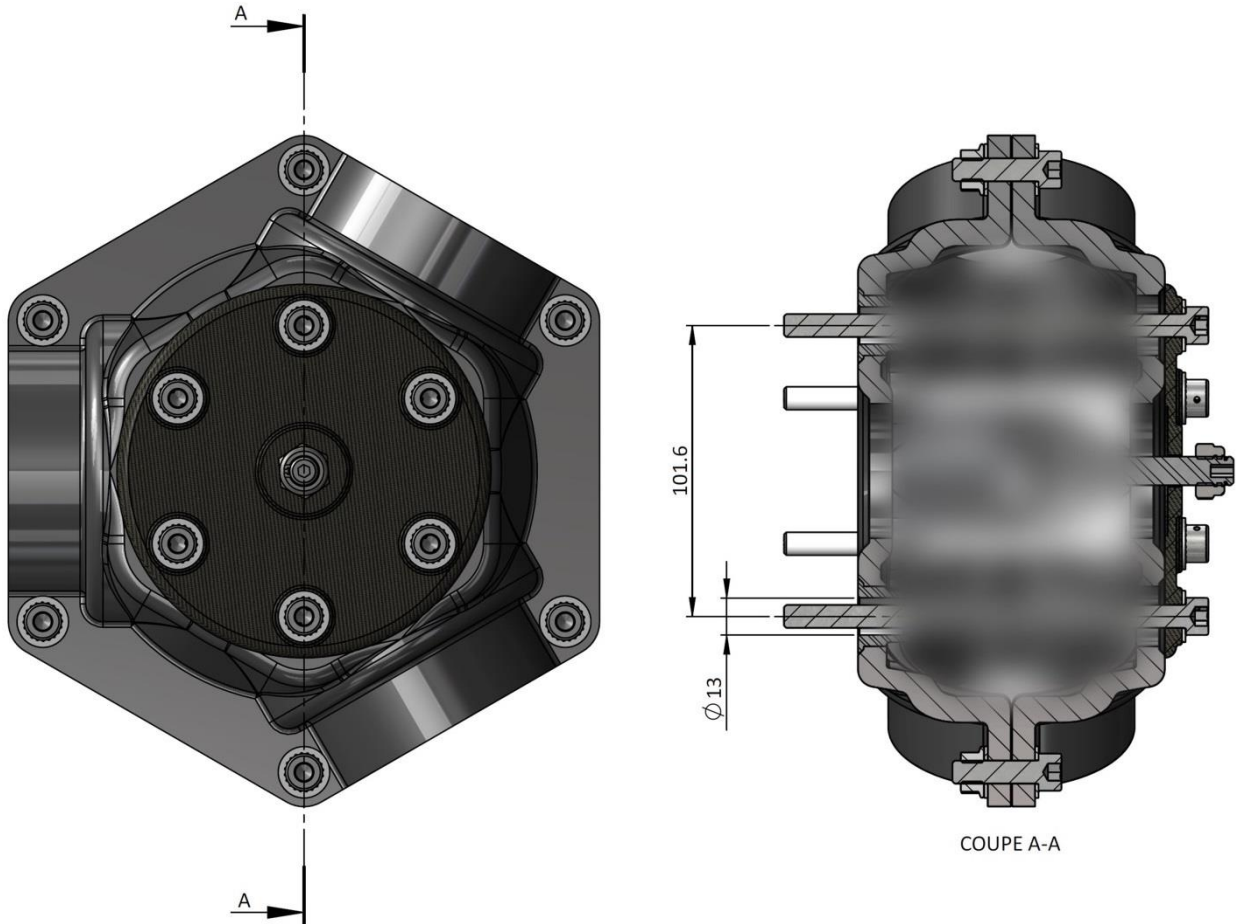

4.2. Hardware

For mounting of the propeller on Rotax engine:



- **Hub assembly:**
Screws/washer CHC M8x30 in grade 5 titanium
Nylstop nut in grade 5 titanium
- **Propeller fixation:**
Screws CHC M8 in grade 5 titanium with a drilled head for a stop with safety wire (adapted screw length according to the direct mounting of the propeller shaft or spacer) / pin contact washer.
- **Adjustable low pitch stop:**
Nylstop nut in grade 5 titanium
- **Tightening washer:**
Perforated carbon Ø8mm on Ø101.6mm

4.3. Exploded view for propeller

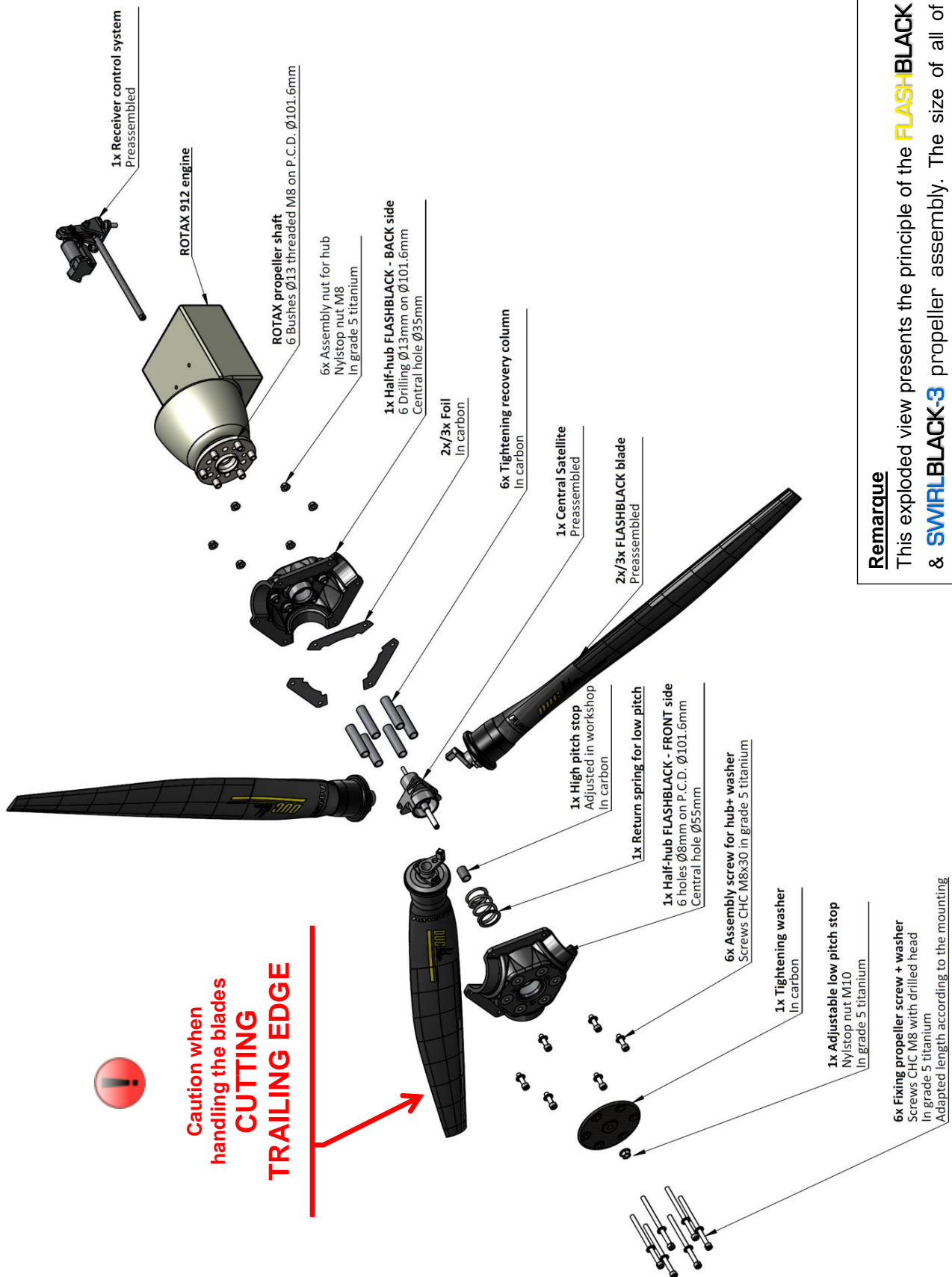

Remarque

This exploded view presents the principle of the **FLASHBLACK** & **SWIRLBLACK-3** propeller assembly. The size of all of these components or number can vary according to the configurations (blade Number, length of the screw ...).

4.4. Control receiver system

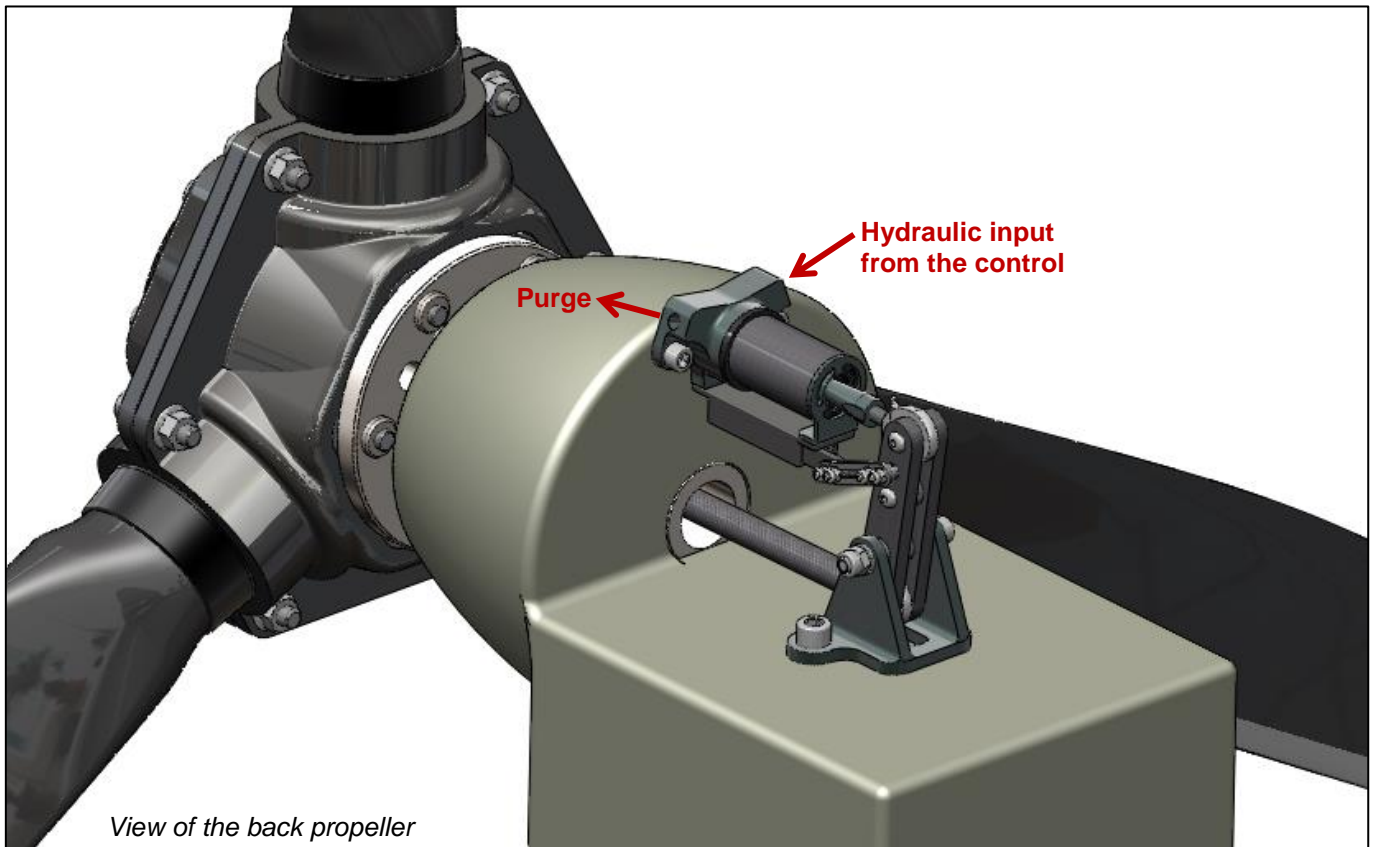
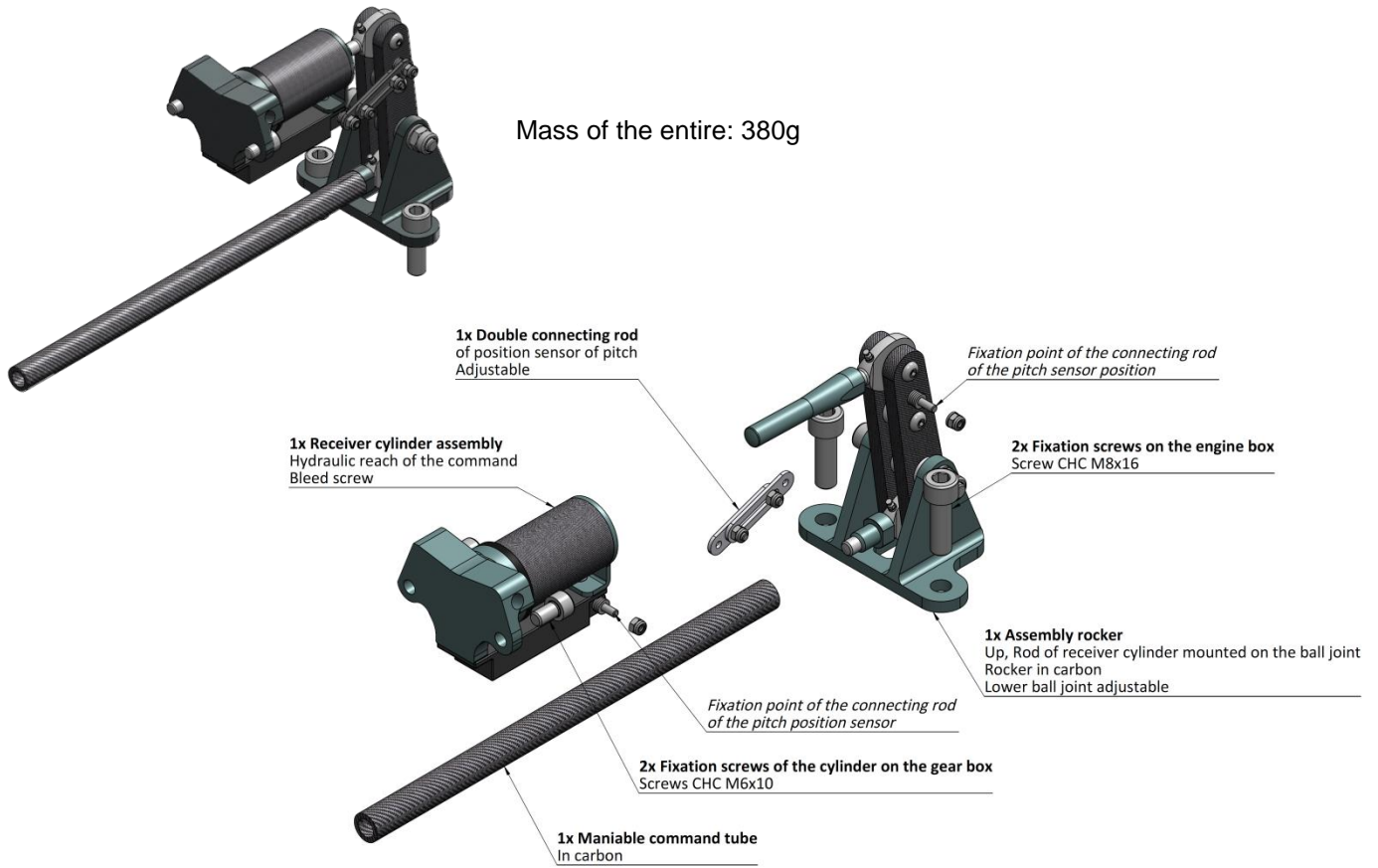

4.5. Pitch controller

4.5.1. Setting wheel (BASE pack)

Description: For accurate adjustment and secure
Advantage: Lightweight and ease of integration
Mass: 180 g

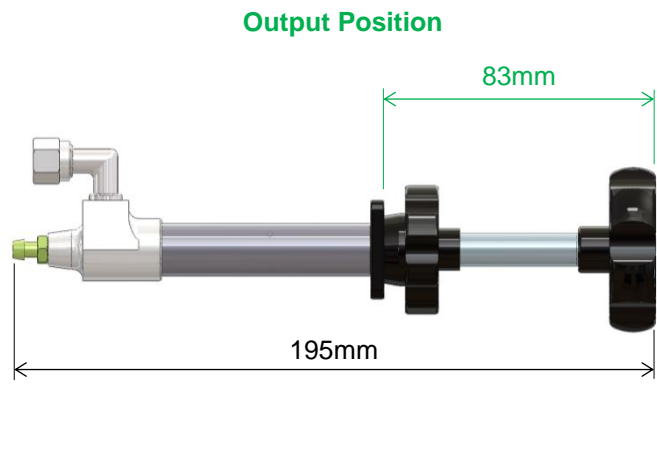
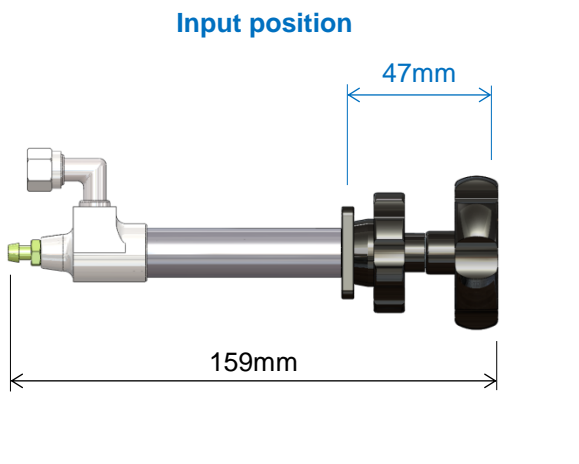
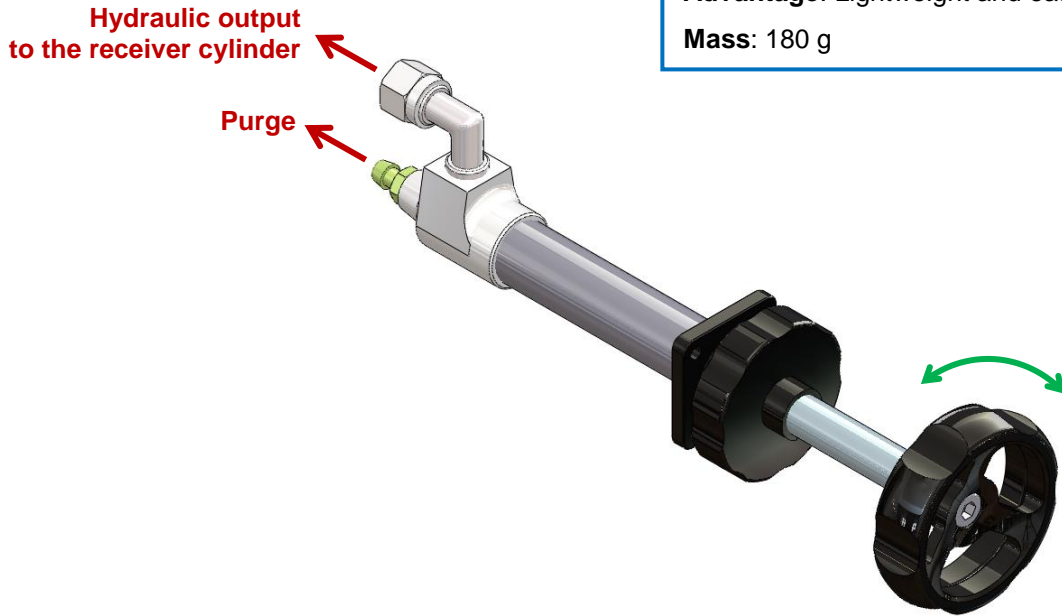

4.5.2. Hydraulic pump (CONSTANT SPEED pack)

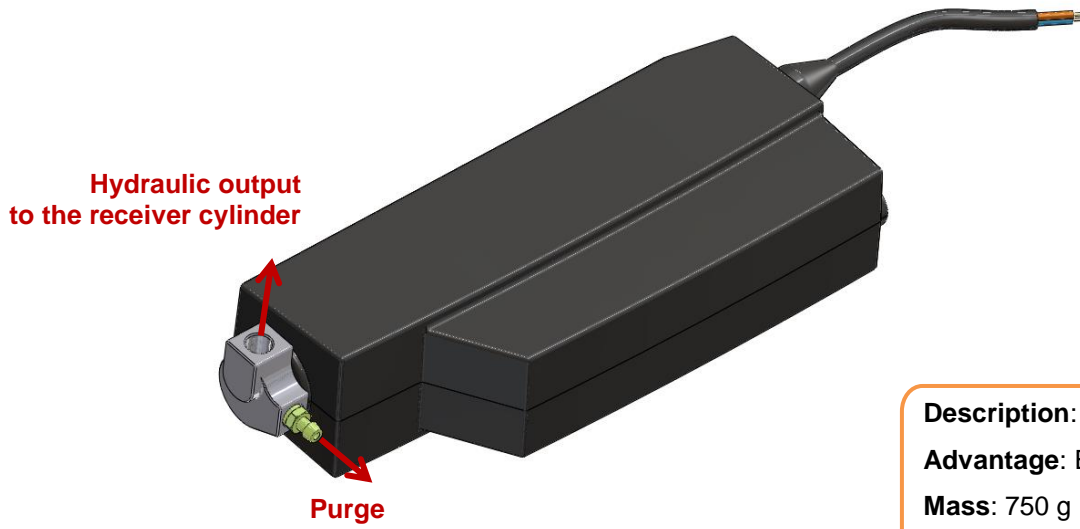

Description: Electric pump
Advantage: Electric management
Mass: 750 g

Dimension:

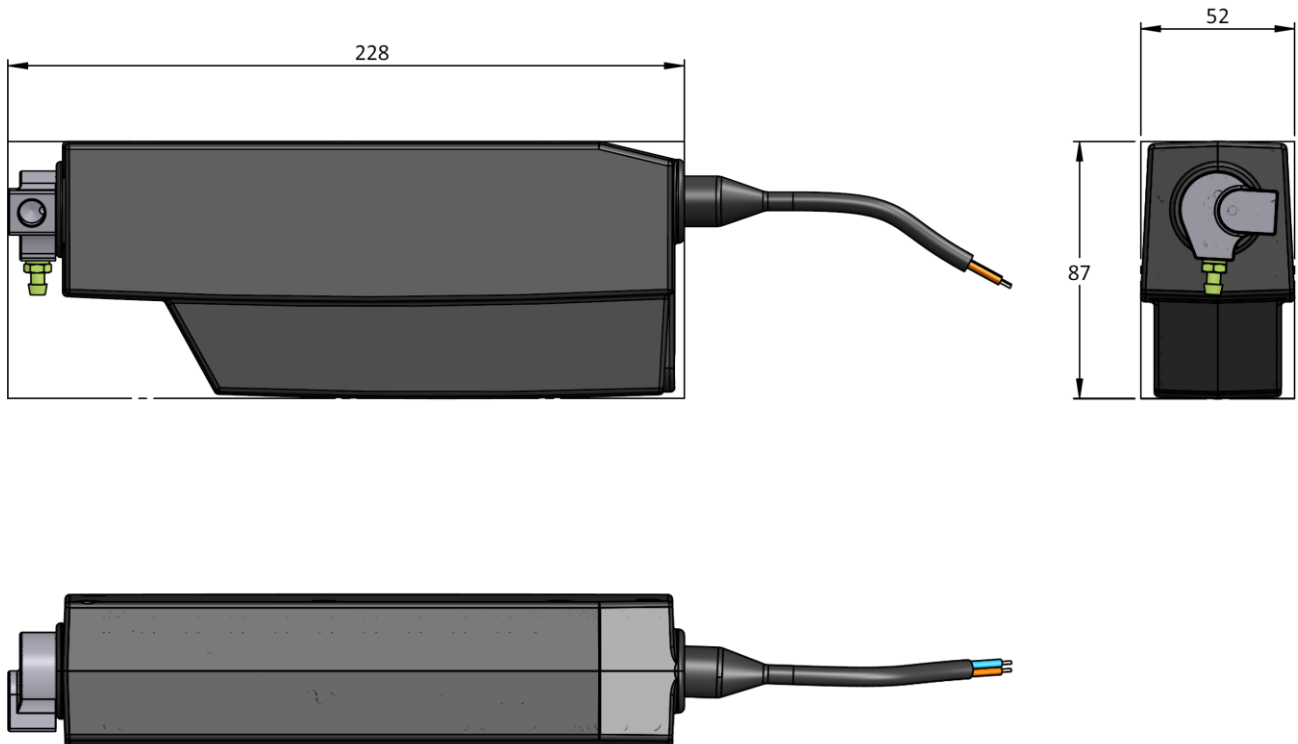

Integration in the cockpit:

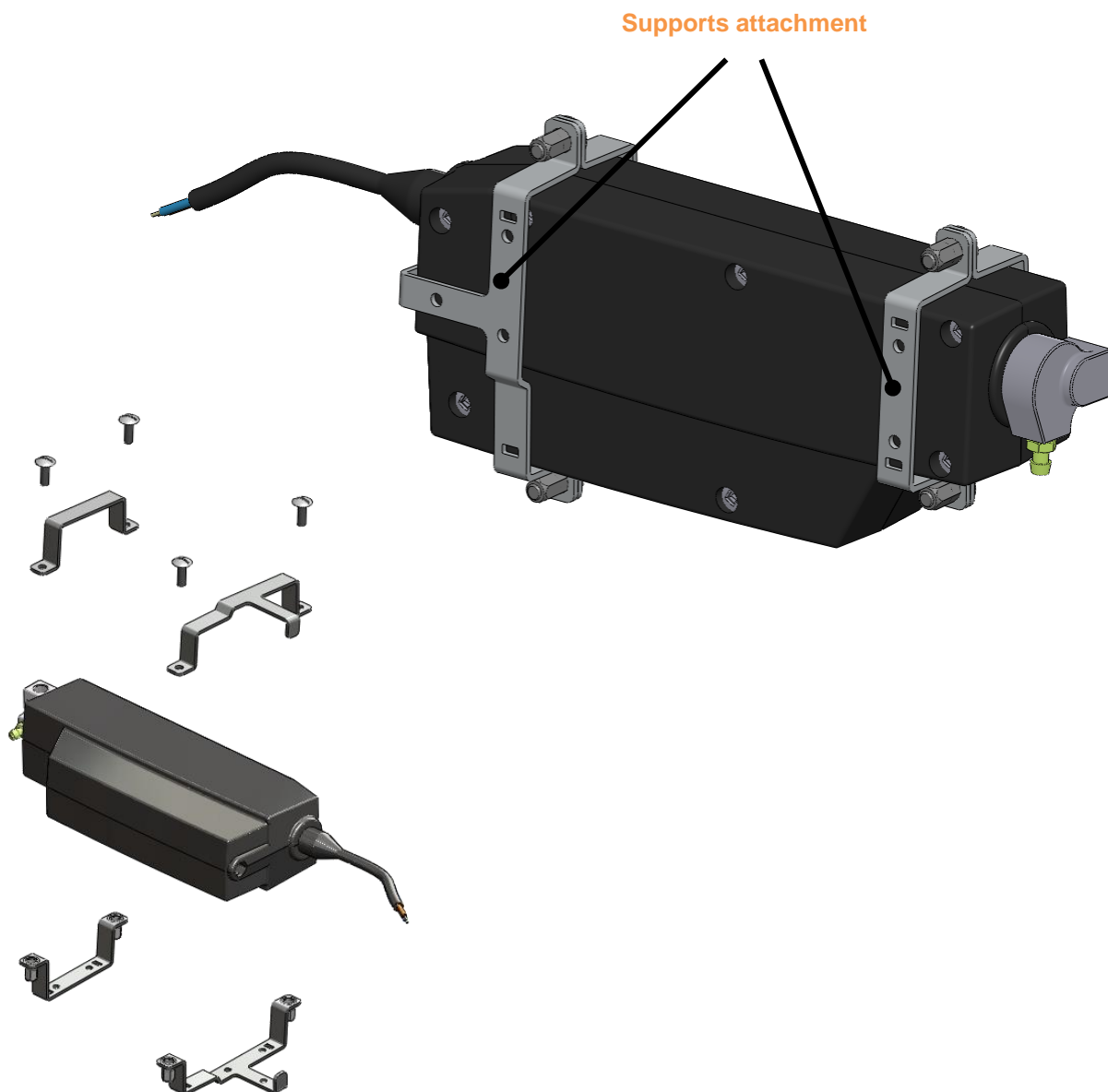
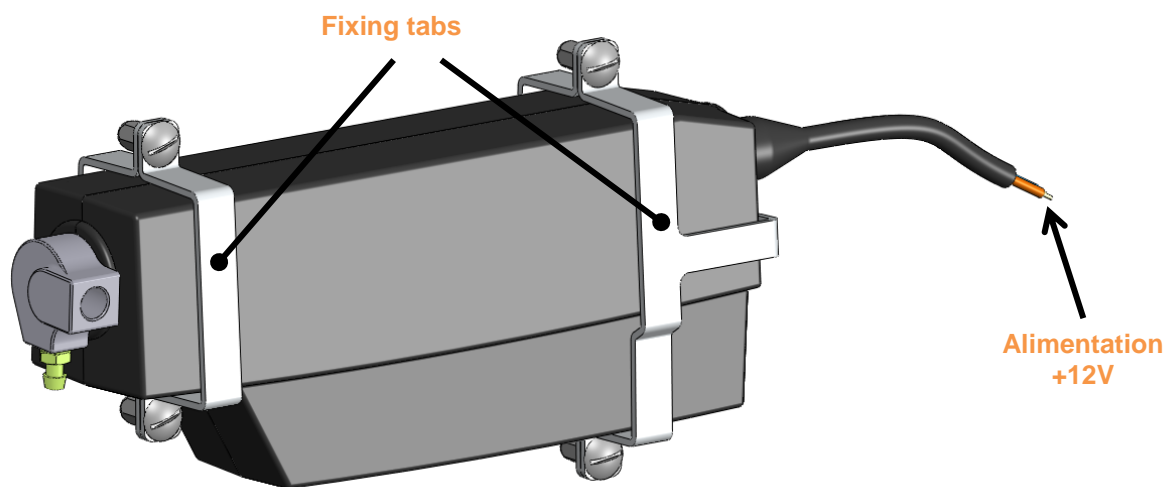

4.5.3. Constant speed box (CONSTANT SPEED pack)

The Constant Speed box (standard avionic size 2-1/4") allows an automatic regulation of pitch propeller to maintain a constant engine speed which is specified by the user.

This regulation system is electric and controls directly the hydraulic pump which is imperative that it be associated.

Its operation is configurable to get the best control system accurate level (+/-20 rpm) with a fast execution.

Consult the utilization and installation manual provided by DUC Propellers Company or the [manufacturer manual](#) on the internet.



Description: Automatic management of the pitch

Advantage: Ease of utilization and performance

Mass: 180 g

Example of use in flight:

- Before the take-off, adjust the engine speed at the maximum, 5700 rpm.
- During the take-off, the engine must reach its maximum rotation speed according to the propeller. In other words, it's recommended to have an engine rpm between 5600 and 5700 rpm.
- During the initial ascent, maintain of conditions.
- In cruise, adjust the desired engine speed by the wheel turn or INC/DEC switch.

For example, you can reduce the engine speed until 4800 rpm and keep an important power. Thus, unlike a fixed pitch propeller, you have the opportunity to develop more power with an intermediate engine rpm and in full power. **So, it's important your aircraft is equipped with an intake manifold pressure to control the engine load.**

- On landing, **redefine the engine speed to 5700 rpm to obtain the "low pitch"** and perform a short landing with a weak speed.

4.6. Visual indicator of pitch

With the position sensor which is situated on the variable pitch system; it is possible to have a visual indicator of pitch present on the dashboard.

The position sensor and the pitch visual indicator are provided with the **FLASHBLACK/-2** & **SWIRLBLACK-3** propeller, but it's also possible to display the pitch position on the EFIS avionic type Dynon Skyview, Garmin G3X...

4.6.1. Position sensor

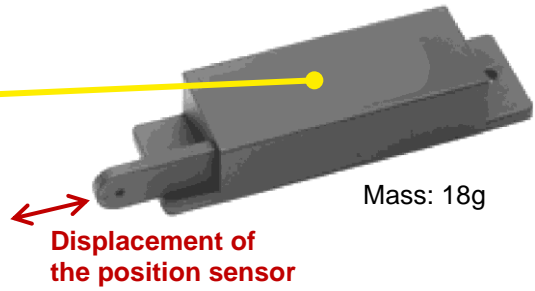
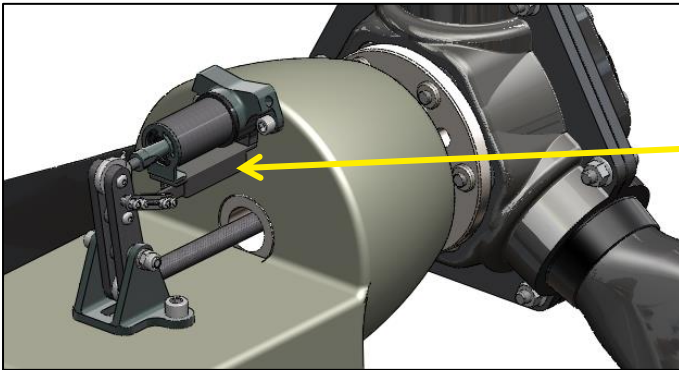

4.6.2. Visual indicator of the pitch

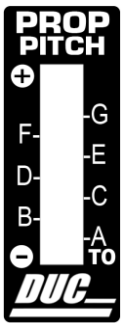

Mass: 20 g

4.6.3. Display of the pitch angle position on EFIS (Ex: Dynon SkyView, Garmin G3X, ...)



Example of Dynon virtual indicator:

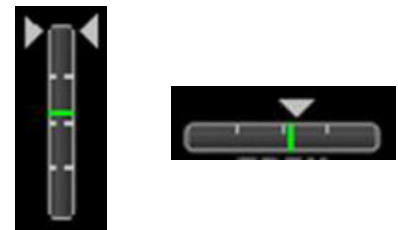

Thanks to contact DUC Hélices to get more instruction about installation and configuration.











5. Mounting instruction of the FLASHBLACK/-2 propeller

The mounting of the FLASHBLACK/-2 & SWIRLBLACK-3 propeller is showed hereafter. It's recommended to assembly the propeller on a table before to install it on the aircraft. The process is the same for the two-blade or three-blade propeller.

for further help, please contact DUC Propellers Company.

5.1. Package contents

The FLASHBLACK/-2 & SWIRLBLACK-3 propeller is sent in kit, composed of subsets. Thanks to perform the verification by checking the good package content:

View	Article	Quantity	DUC Propellers Company Verification	Customer Verification
	Fixation screws of the propeller + Washer Screws CHC M8 with drilled head Adapted length according to the mounting	6		
	Adjustable low pitch stop Nylstop nut M10	1		
	Tightening washer In carbon	1		
	Assembly screw for hub + Washer Screws CHC M8x30	6		
	Front FLASHBLACK half-hub 6 Drilling Ø8mm on Ø101.6mm Central bore Ø55mm	1		
	Safety return spring for low pitch	1		
	FLASHBLACK or SWIRLBLACK-3 blade Preassembled	2 or 3		
	Central satellite Preassembled	1		
	Foil for hub tightening In carbon	2 or 3		
	Back FLASHBLACK half-hub + 6x Tightening recovery column 6 Drilling Ø13mm on Ø101.6mm Central bore Ø35mm	1		
	Assembly nut for hub Nylstop nut M8	6		

View	Article	Quantity	DUC Propellers Company Verification	Customer Verification
	<p>Additional content but necessary for the installation: ROTAX bushes Ø13mm threaded M8 or DUC bushes Ø13mm drilled Ø8mm + Nylstop nut M8 + Washer</p>	6		
	<p>Control receiver system Preassembled 2x Fixation screws CHC M6x10 for cylinder on gearbox 2x Fixation screws CHC M8x16</p>	1		
	<p>Tube removable control In carbon Variable length according to the presence or not of a spacer</p>	1		
	<p>Hydraulic link</p>	2 to 3 m		
	<p>DOT4 brake fluid(Optional)</p>	1		
	<p>Visual indicator of the pitch + cable harness</p>	1		
	<p><input type="checkbox"/> Wheel (BASE pack)</p>	1		
	<p><input type="checkbox"/> Lever (LEVER pack)</p>	1		
	<p><input type="checkbox"/> Hydraulic pump + fixations (ELECTRIC & CONSTANT SPEED pack)</p>	1		
	<p><input type="checkbox"/> Switch (ELECTRIC pack)</p>	1		
	<p><input type="checkbox"/> Constant speed box + Cable harness (Optional) (CONSTANT SPEED pack)</p>	1		

5.2. Operator & List of required tools

For the mounting of the propeller, it's recommended to be 2 operators for certain operations.

Here, the list of required tools:

- Dynamometric Allen key 6 (Torque: 20 and 25 Nm)
- Allen key 3
- 2x Spanner 8
- Spanner 13
- Brake bleeder + Receiver bottle
- Support drilled Ø30 to 50mm for the mounting of the propeller on table
- Dynamometric flathead screwdriver (Torque: 4 Nm)



5.3. The assembly of the propeller on table

↓ Check the steps gradually:

STEP 1.



Place the “engine back half-hub” (Central hole Ø55mm) on a table.
Be careful not reverse with the “propeller front” half-hub.

STEP 2.

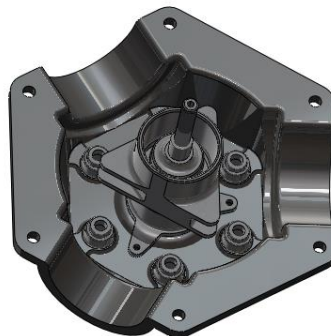

Laid the **satellite** in the back half-hub without fitted into the carbon hole Ø35.
Check if you respect the right direction of the satellite's mounting.

STEP 3.

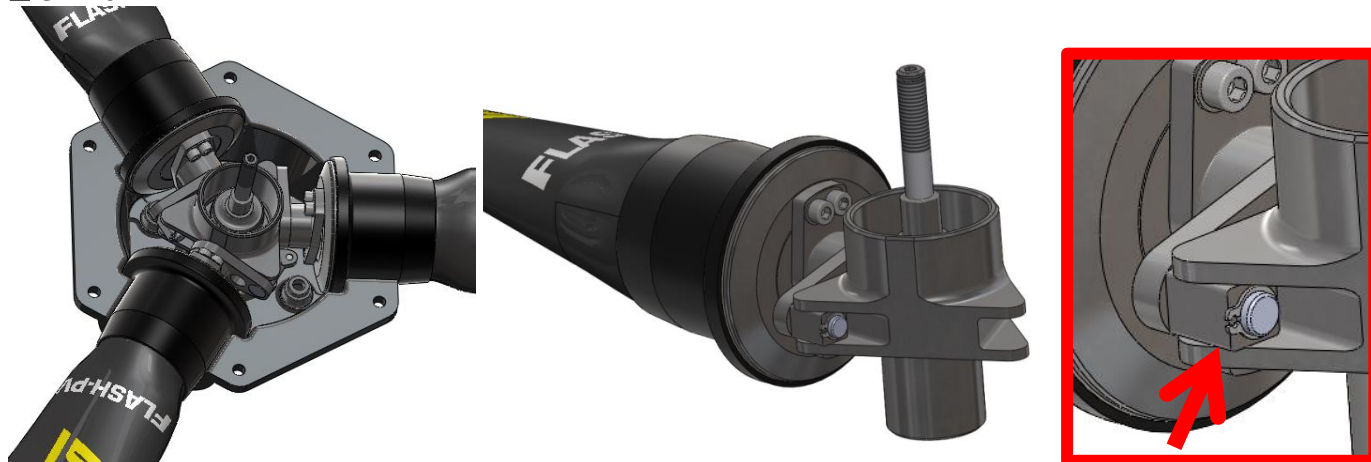

While keeping the satellite laid on the back half-hub, slot the **FLASHBLACK/-2** & **SWIRLBLACK-3** blades one after the others into the satellite groove and into the back half-hub.

Place the DUC sticker in front of you.

Caution, the snap ring (circlip) should be facing out of the assembly.

□ STEP 4.



Place the 2 (2-blade) or 3 (3-blade) carbon foils on the flat of the back half-hub.
Be careful with the manipulation, fragile parts.

□ STEP 5.



Front half-hub

Ensure the good introduction of the blades in their place.
Place the **front half-hub**. This one must include 6 **carbon tightening recovery columns**.
Watch if the parts are aligned for the assembly.

□ STEP 6.



Place the **Screws CHC M8x30 + Washer** over the top and the **Nylstop nut** behind for the assembly of the 2 half-hubs.

Make a first tightening to approach the screws.

Check if the blades are well placed in their place.

Pull slightly the blades outwards for a good placement of the blades.

□ STEP 7.



Add the **safety return spring** in low pitch.

□ STEP 8.

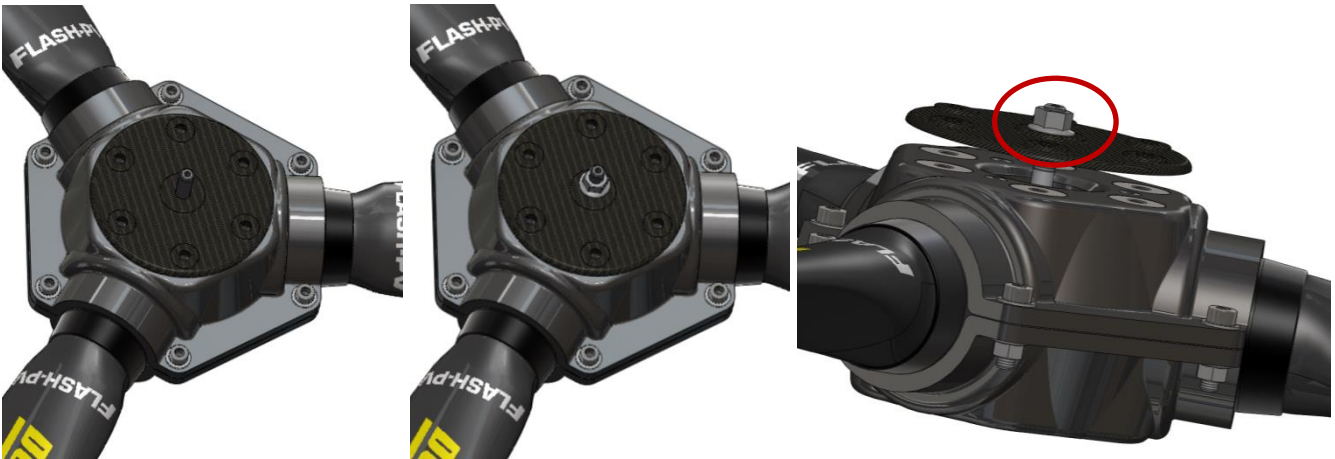

Place the **tightening washer in carbon**.

Put the safety return spring in compression by pushing the carbon washer and screw the **Nylstop nut M10 at the beginning of this one and keep this position for the M10 nut until the setting of the propeller.**

□ STEP 9.



Put the **6 Fixation screws CHC M8 + Washer** in the fixations drillings of the propeller.

At this point, the propeller is pre-assembled on the table but not tight.

5.4. Installation on the aircraft

5.4.1. Direct installation on the aircraft

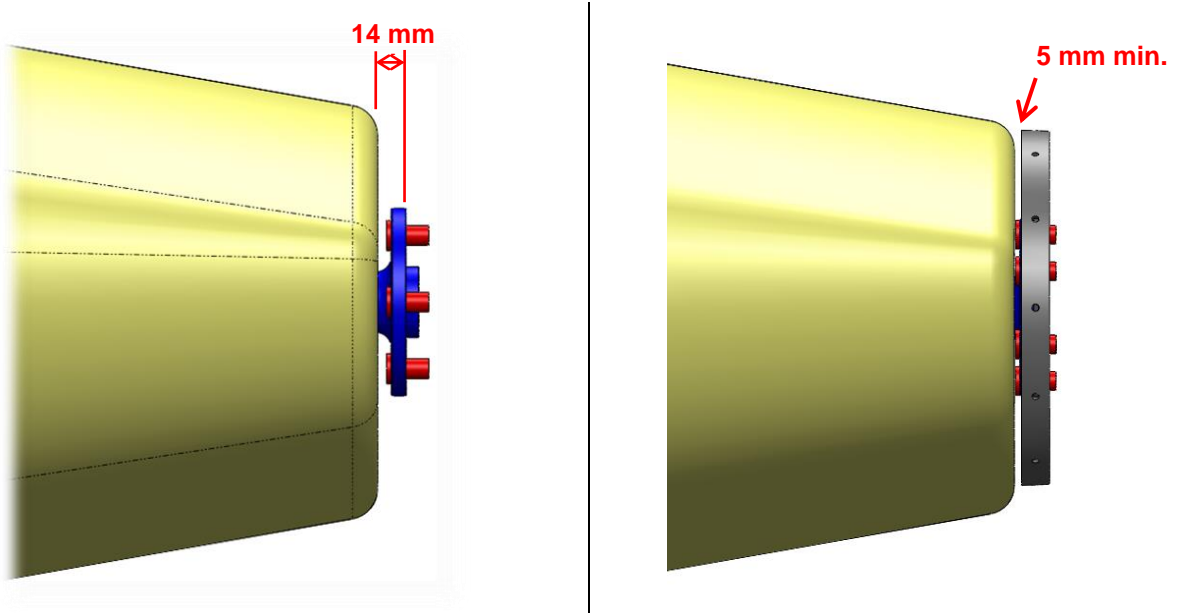

5.4.2. Use of a spacer

Determination of the spacer length:

Measure the **distance X** between the propeller-shaft and the engine hood limit, then add **14mm**.

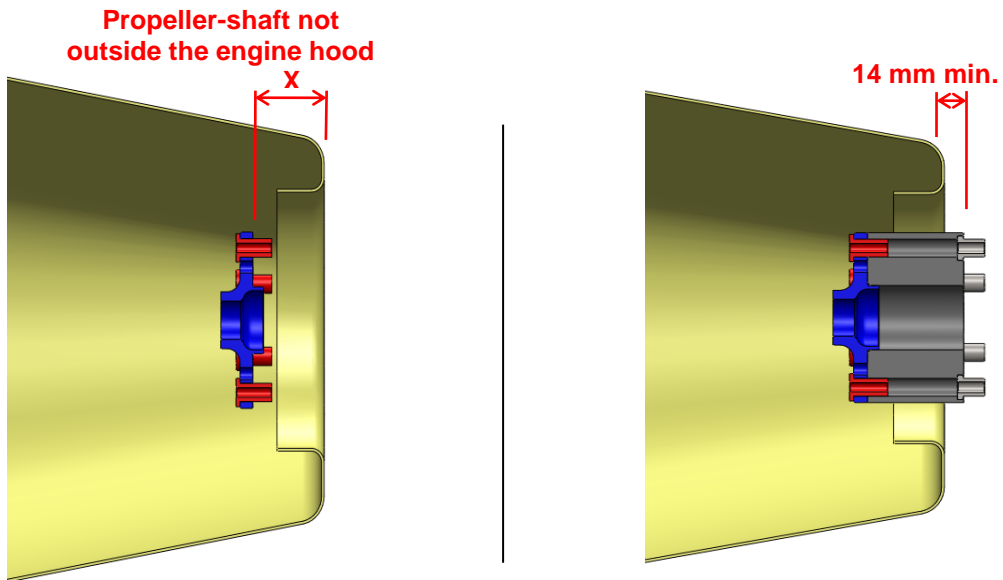

Available spacer:

Engine	Model	Length
ROTAX	912H spacer	3, 6, 10, 15, 20, 30, 45, 50, 60, 70, 80, 100, 120mm

5.5. Installation of command receiver system

□ STEP 10.

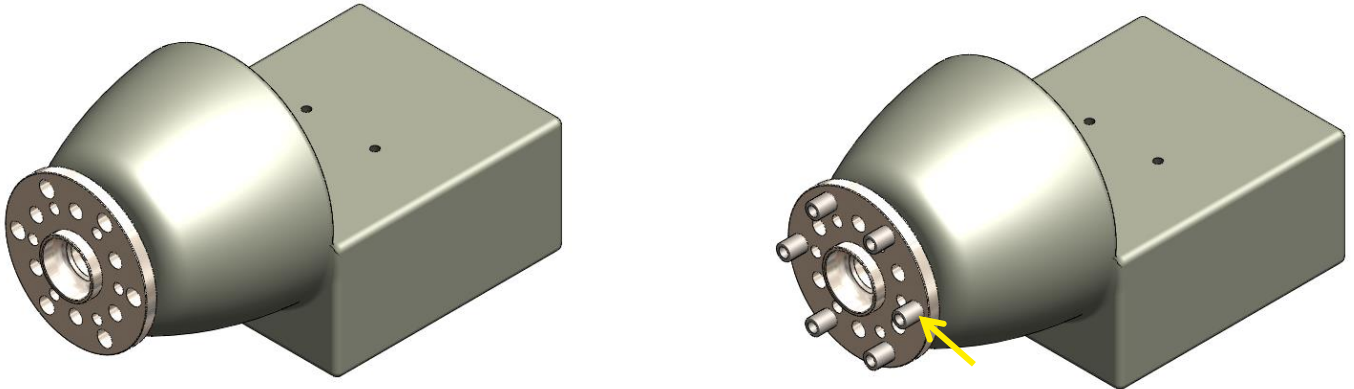

The ROTAX propeller shaft **must be** equipped with **indexing bushes Ø13mm** for the correct mounting of the propeller. According to the type of mounting (direct mounting or with spacer), the bushes Ø13 can be threaded in M8 or only drilled Ø8mm. In the second case, it's necessary to use a locknut for the fixation of the propeller.

□ STEP 11.

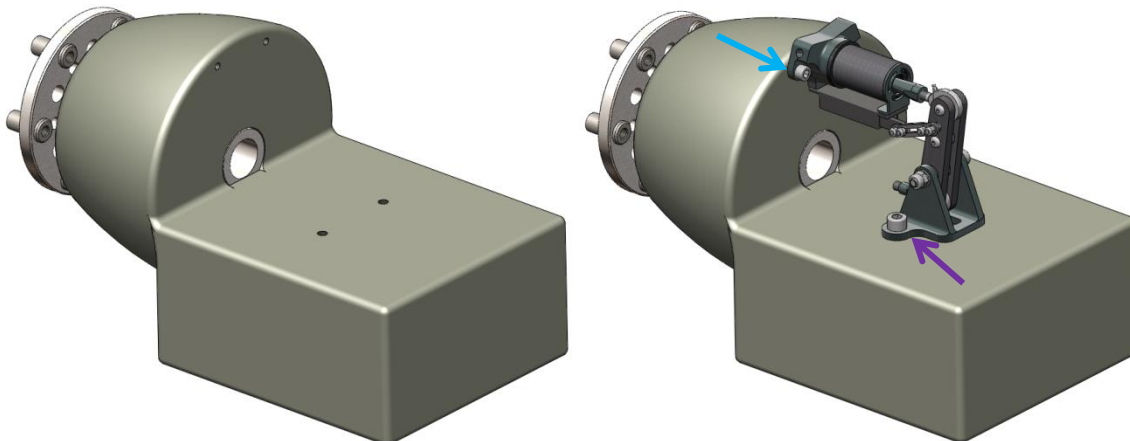

Install the control receiver system with **2 screws CHC M6x10 (Tightening torque 10 N.m)** on the gear box (vertical face) and **2 screws CHC M8x16 (Tightening torque 16 N.m)** on the engine box (horizontal face). **Caution, it is necessary to have sufficient space around the receiver system to allow proper operation.**

□ STEP 12.

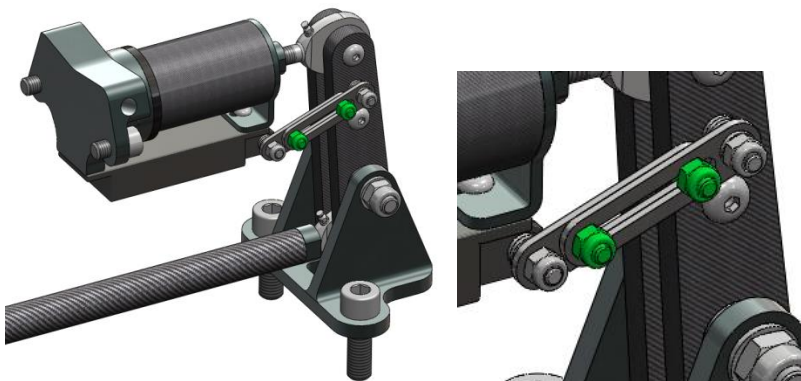

You must loosen the assembly screws of the connecting rod which adjust the position sensor.
In case of forgotten, the system can break.

□ STEP 13.

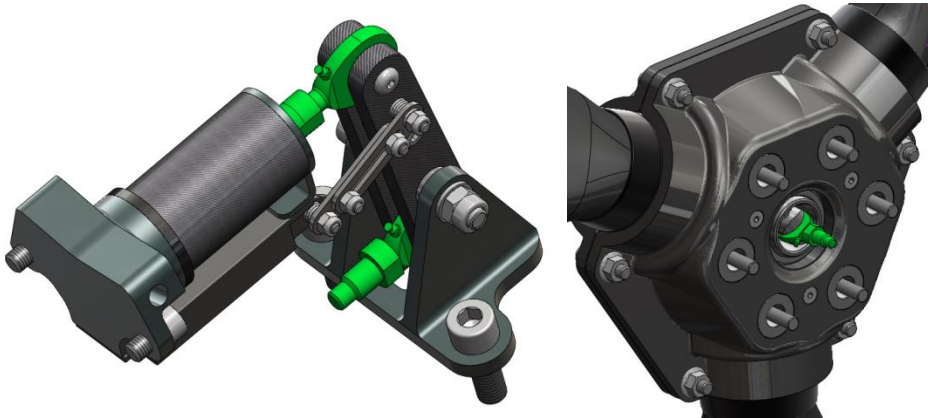

Check if the 2 balls joint of the rocker are totally inserted/screwed and that the locknuts are completely tightened. Do the same checking on the satellite balls joint at the back of the propeller.

□ STEP 14.



Determining the length of the control tube:

Mounting	Spinner mounting plate thickness	Spacer thickness	Command tube length
Without spinner Without spacer	0mm	0mm	270.5mm
DUC spinner only	2.5mm	0mm	273mm
DUC spinner + Xmm spacer	2.5mm	Xmm	273+Xmm

Place the carbon command tube on the tip at the back of the propeller. **Be careful, the command tube length is defined according to the type of mounting of the propeller (direct mounting or with spacer). Check if the initial mounting configuration is respected.**

□ STEP 15.

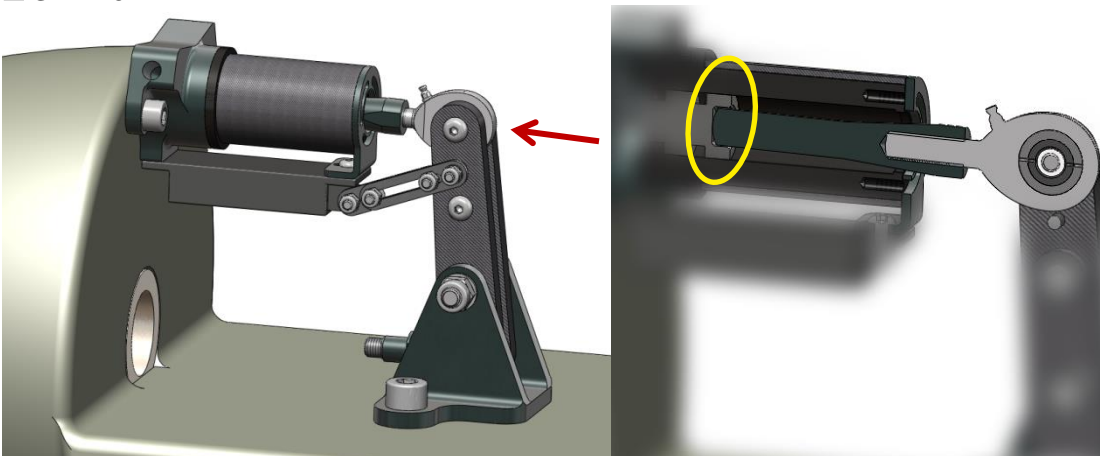

Insert completely the command receiver cylinder. **Be careful, check if the cylinder rod is centered in the piston.**

□ STEP 16.

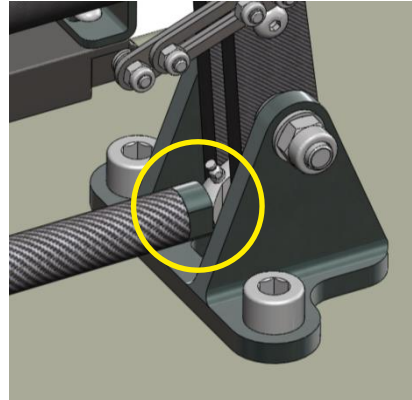
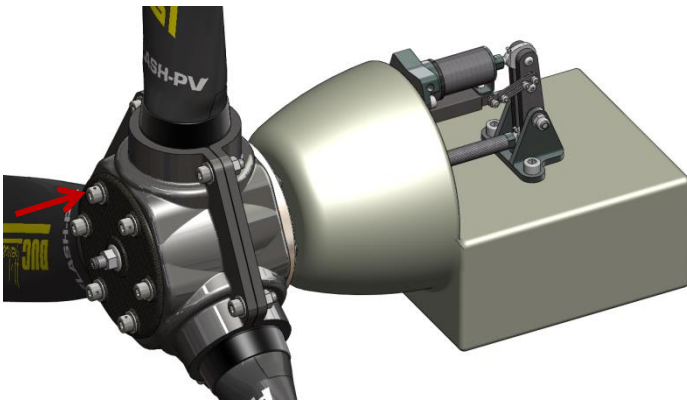

With the 6 screws CHC M8 + Washer, fixed the **FLASHBLACK** or **SWIRLBLACK-3** propeller on the ROTAX propeller shaft with the carbon command tube which is installed before and **make a first slight tightening**. After crossing the gear box, this tube must fit with the lower ball joint of the control receiver system. **Check if there isn't strength on the carbon tube during assembly/disassembly.**

□ STEP 17.

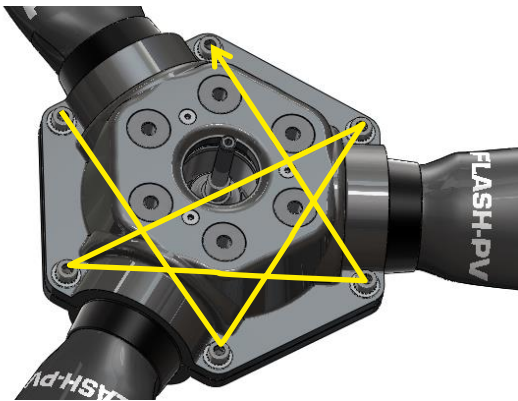

Now, make a **progressive tightening in cross** in 2 or 3 times to reach the **tightening torque 25 N.m**.

TIGHTENING TORQUE
2,5 Kg/m 25 N.m

□ STEP 18.

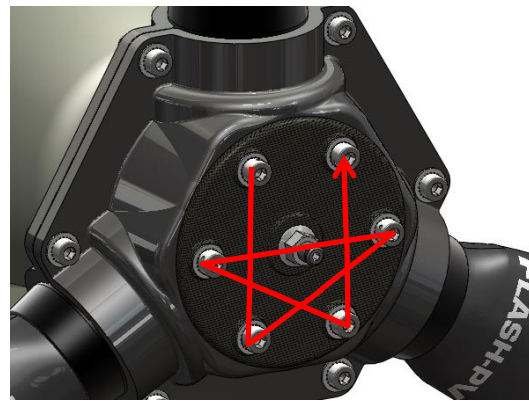

Gradually tighten in 2 or 3 times the 6 CHC M8 propeller fixing screws at 20 Nm.

TIGHTENING TORQUE
2,0 Kg/m 20 N.m

At this point, the propeller is preinstalled on the ROTAX engine.

5.6. Installation of the hydraulic command and visual indicator

5.6.1. Setting wheel (BASE pack)

Recommended place: Dashboard, easily maneuverable, on a rigid surface

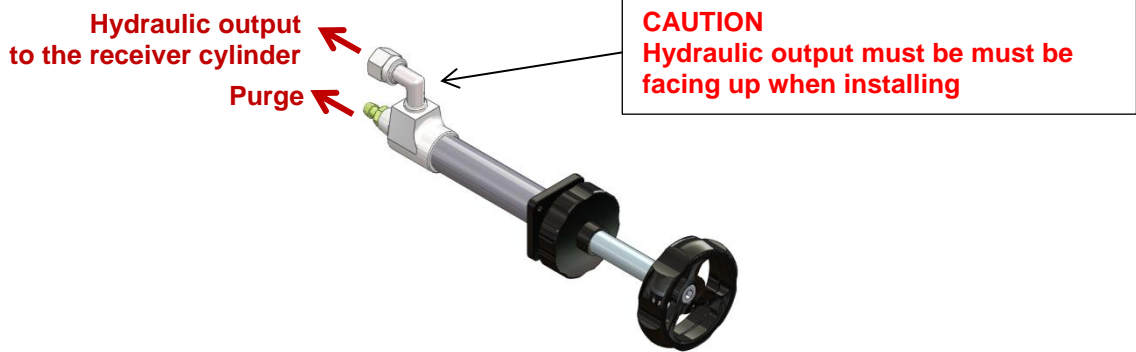

Mounting interface on the dashboard:

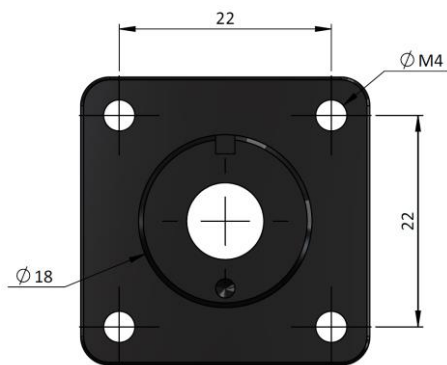

Drilling recommended for integration dashboard:

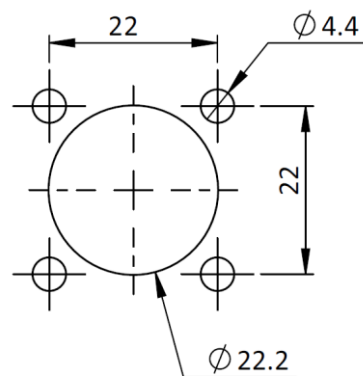

Scale drawing 1:1

5.6.2. Hydraulic pump (CONSTANT SPEED pack)

Recommended direction: Pump axis inclined by about 5°

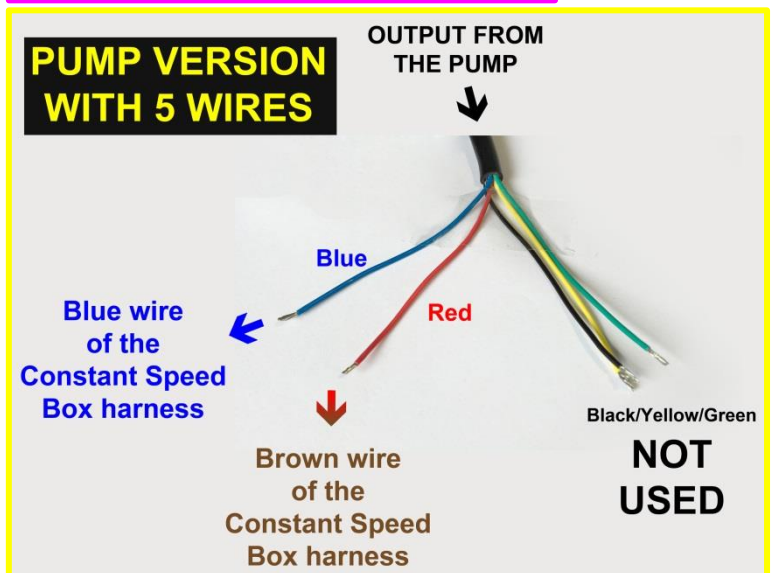
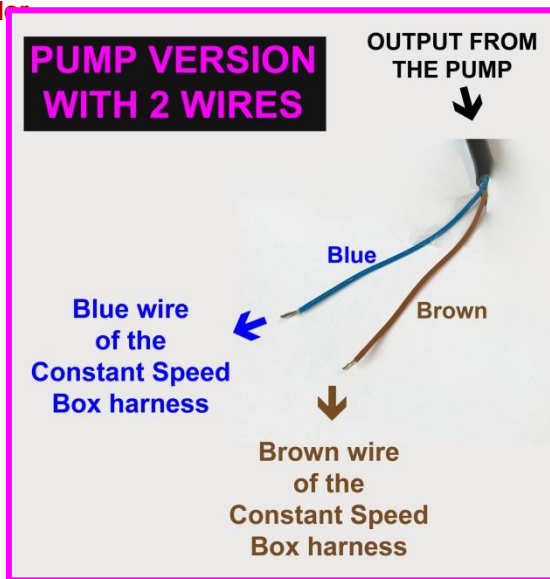
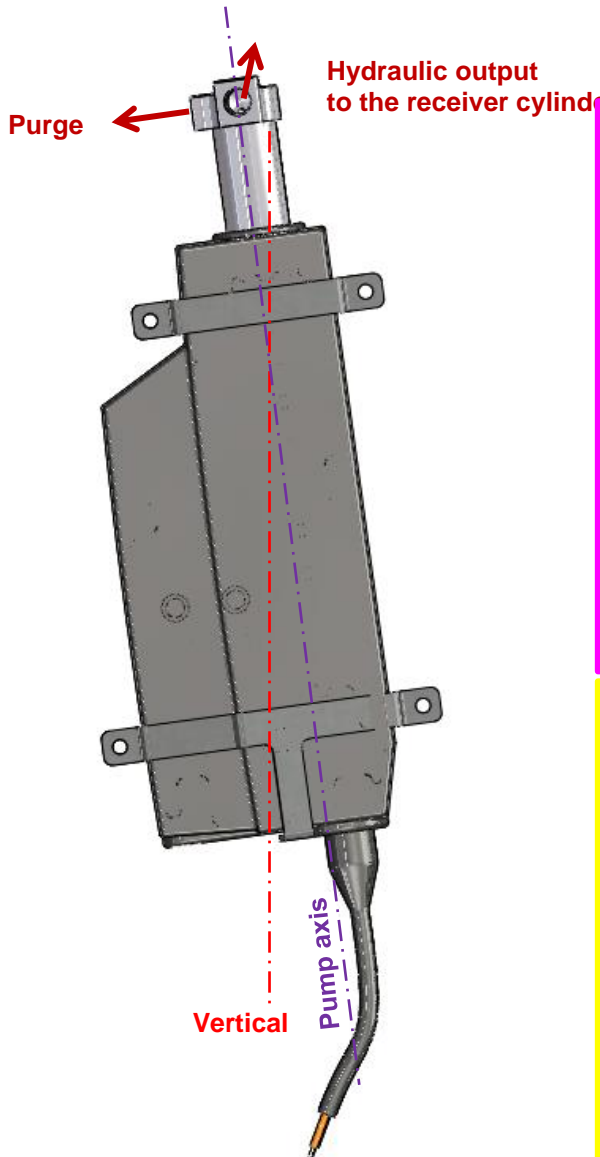
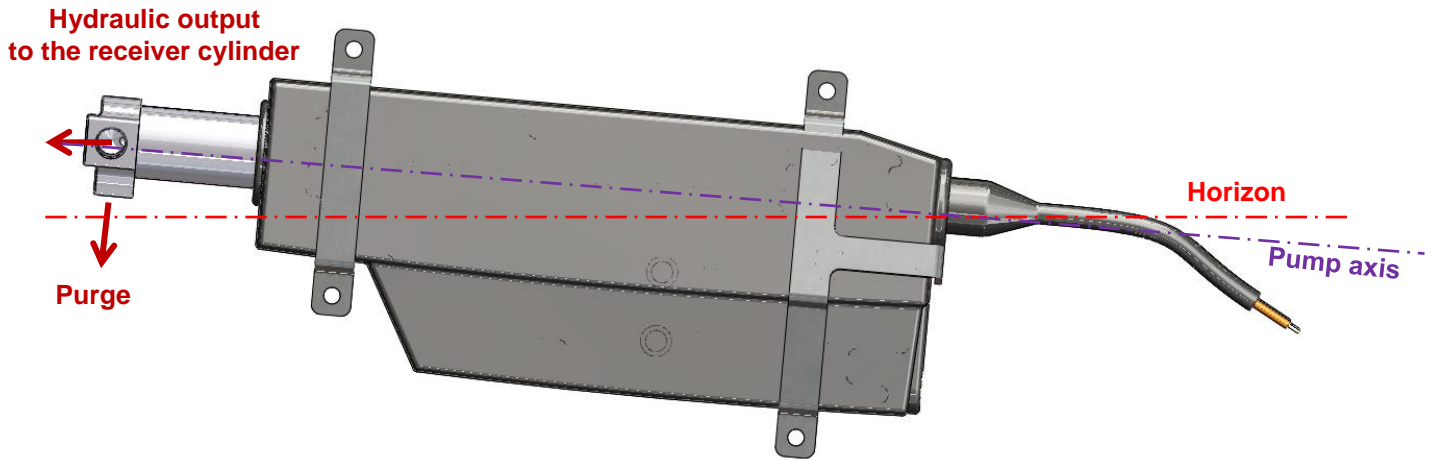

5.6.3. Constant speed box (CONSTANT SPEED pack)

Consult the utilization and installation manual provided by DUC Propellers Company or the [manufacturer manual](#) on the internet.



Engine speed specified by the pilot

Engine speed measured

Recommended cutting for dashboard integration:

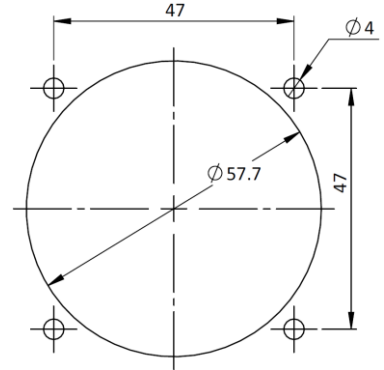

Harness wiring diagram:

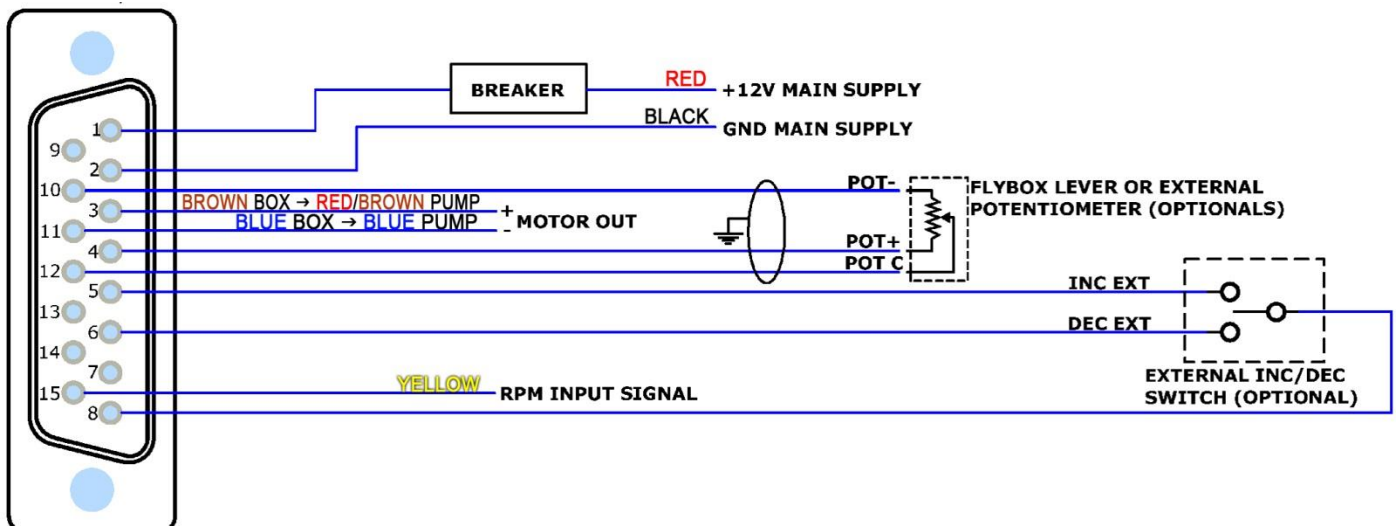

15-pole female connector, view from wiring side

- 1= +12V Main supply
- 2= GND Main supply
- 3= Motor out (+)

- 4= POT + (positive) for external lever/potentiometer (optional)
- 5= "INC EXT" signal for external INC/DEC switch (optional)
- 6= "DEC EXT" signal for external INC/DEC switch (optional)
- 7= not used/reserved
- 8= GND for external INC/DEC switch (optional)
- 9= not used/reserved
- 10= POT - (negative) for external lever/potentiometer (optional)

11= Motor out (-)

- 12= POT C (cursor) for external lever/potentiometer (optional)
- 13= not used/reserved
- 14= not used/reserved

15= RPM input signal from the pick-up (for ROTAX912/914 engines) or from ECU (for EPAPOWER engines)

5.7. Visual indicator of pitch



Mass: 20 g

Cutting recommended on the dashboard:

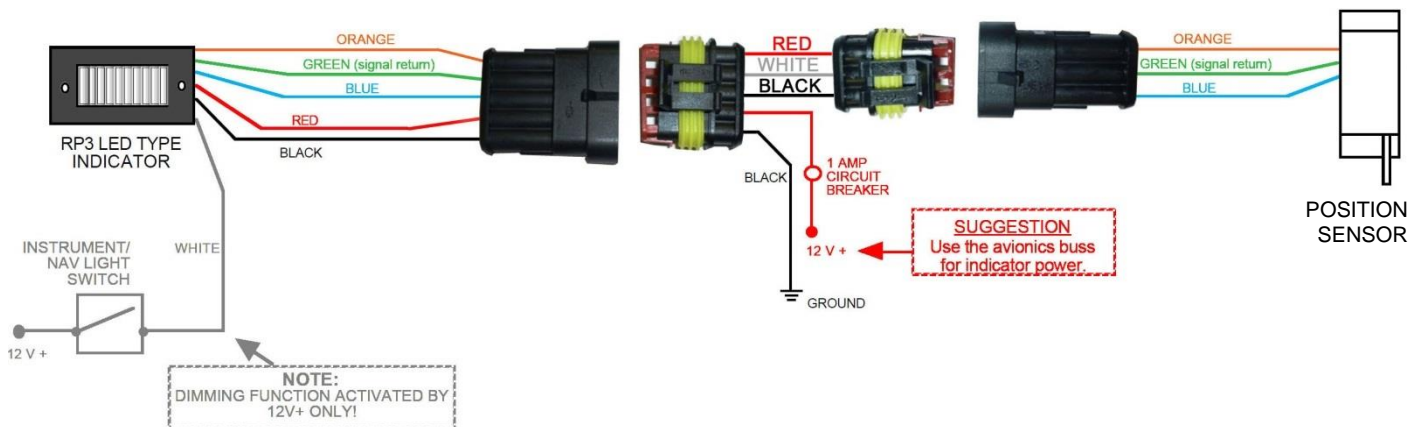
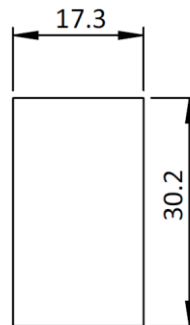

5.8. Execution of electrical wiring

5.8.1. Pitch indicator with the position sensor

Connect wire harnesses provided for this purpose.

5.8.2. **CONSTANT SPEED** pack: Hydraulic pump & Constant Speed box

After the installation of the Constant speed box on the dashboard, wire on the cable harness, provided with this box, the engine alimentation and the ROTAX engine wire allowing to get the information of the engine speed.

In option, the Constant speed box can be controlled with a second switch install into a binnacle or on the flight command handle.

5.9. Installation of the hydraulic system

5.9.1. Preparation

BASE pack: Hydraulic control wheel

- 1) Before the hydraulic connection, unscrew completely the wheel (output position).

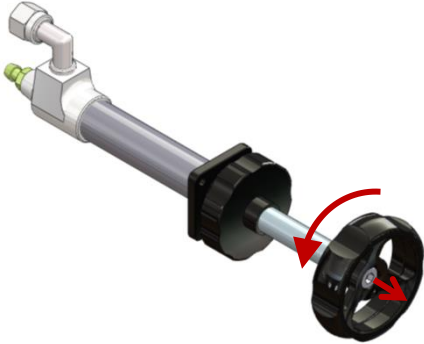

- 2) Unscrew completely the bleed screw thanks to a spanner 8.

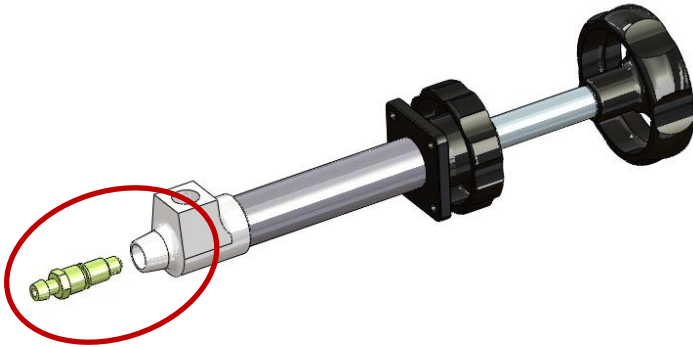

- 3) With an Allen key 3 (or similar tool), put this tool in the place of the bleed screw to push the piston until the stop, placed inside against the threaded rod.

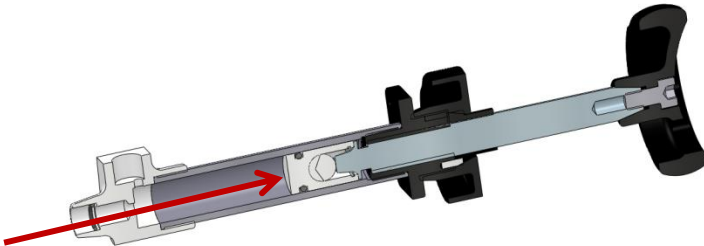

- 4) **Keep out the wheel during all installations.**

- 5) Put the bleed screw and tighten normally.



CONSTANT SPEED pack: Hydraulic pump

In the case of the Constant Speed box, switch to manual mode (1) and activate the engine (2) to place it in MIN stop (LED on (3)).



It will be necessary to check the direction of operation for next steps in case if there is an inversion of electrical wire.

5.9.2. Hydraulic connection



Implement the supplied hose and adjust the length according to the installation. Keep a margin to avoid tension.

Then, connect the hose with fittings present on the control and the receiver cylinder.

We recommend that you follow the detailed explanations provided by the company BERINGER in the case of the installation of their brake system (the type of connector and hose are similar).



BERINGER AERO, Aéroport, F-05130 Tallard
 Tel : +33 (0) 4 92 20 16 19
 contact@beringer-aero.com

Assembly instructions for hose and banjo fittings

Date de révision
 31 Janv 2014

Page 1/2

1) Preliminary:

Tools needed to make a brake line:

- click-type torque wrench
- fine screwdriver
- Cutter plier

2) Safety instructions:

Brake lines must be made carefully. In the purpose to ensure an optimal safety of the brake system, the lines must be done as describe next.

In case of any question or problem, please contact BERINGER.

1 A banjo fitting is made of the 3 following parts :

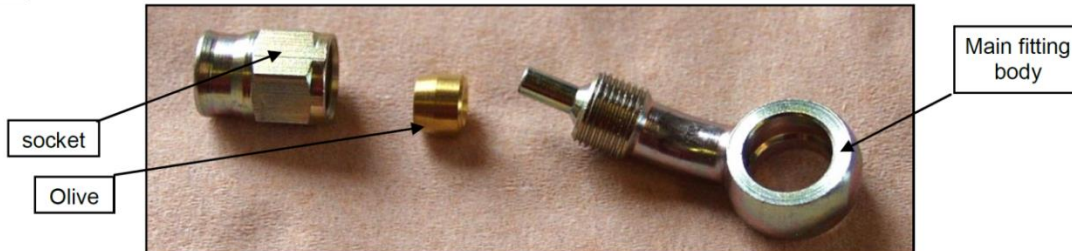

2 Cut the hose to the required length :

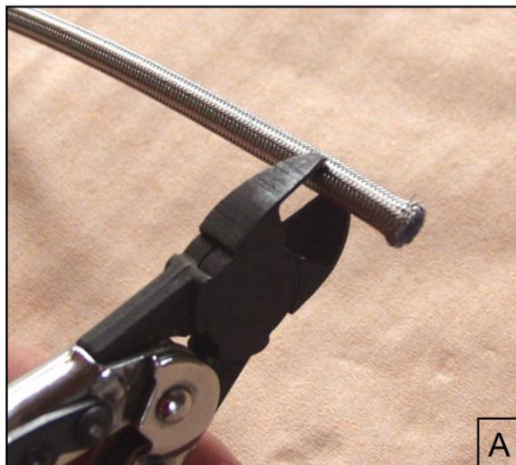

- Using a fine tooth saw blade or cutter plier, cut hose to the required length.
- Clean any loose debris from both the cut ends and inside the hose.
- Then use a flat pliers to make the hole circular, as shown on the picture below.



WARNING concerning the installation of the stainless steel braided hose in a tube or in the landing gear leg:

Due to the stainless steel braid, when you cut the hose, the two sides of the hose are not identical:

- On one side the braid retracts and it becomes easy to insert it into a tube or into the landing gear leg.
- On the other side, the braid expands and it is difficult to insert it in any tube or LG leg.





BERINGER AERO, Aéroport, F-05130 Tallard
Tel : +33 (0) 4 92 20 16 19
contact@beringer-aero.com

Assembly instructions for hose and banjo fittings

Date de révision
31 Janv 2014

Page 2/2

- 3** Push one socket over the overbraid working and flare out end of stainless steel from the PTFE inner tube.



Flare out stainless steel from PTFE tube
(5mm length min.)

Use a fine screwdriver

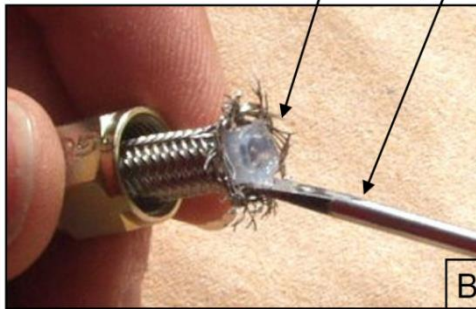

- 4** Insert the olive



Push the olive onto the end of PTFE inner tube and under the stainless steel braid. **Make sure that all stainless steel filaments are outside of the olive.**

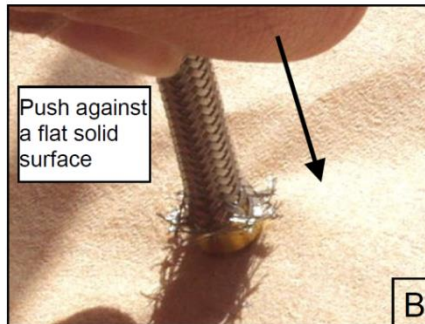

Push against a flat solid surface

PTFE tube must be in contact with the olive

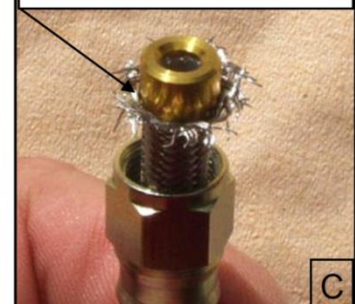

Make sure that PTFE tube is fully homed in the olive.

- 5** Insert main fitting body

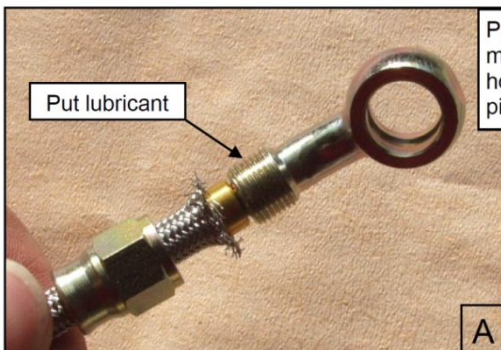

Put lubricant

Push between hands the main fitting body and hose as shown on left picture.

Turn with hand the main fitting body to start threading the socket as shown on picture below.



- 6** Finish tightening the socket onto the fitting

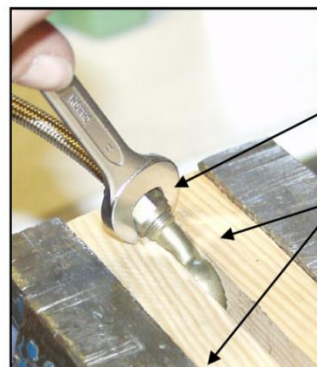

Torque tightening the socket at 10N.m to 15N.m (90 IN-LBS to 132 IN-LBS)

Maintain with wood plates to preserve the main fitting body

5.9.3. Bleeding of the hydraulic system (valid for all the packs)

Preliminary instruction:

Be sure to keep the **screws sensors** of the link settings loosened to allow mobility.

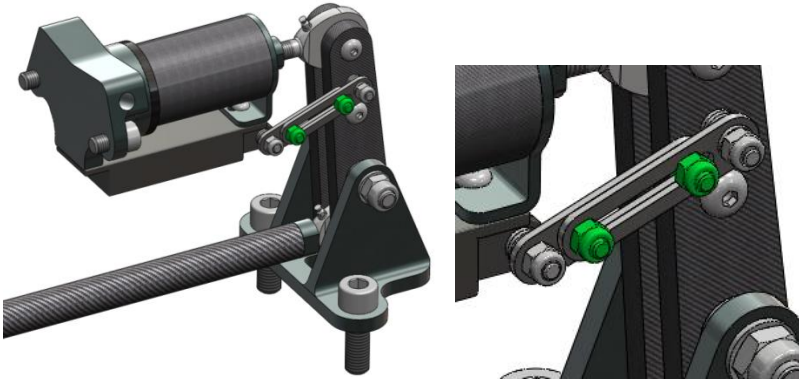

The purge of the system must be performed with a brake bleeder system and a receiver tank. (Available on request from DUC Propellers Company).

1. As explicated below, the command hydraulic cylinder must be in output position.



2. Also, check that the piston of the receiver system is correctly inside the cylinder.

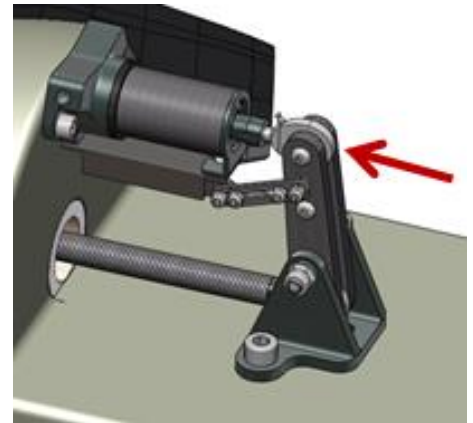

3. Check the tightening of all hydraulic links and the bleed screw before to continue.

4. Place the receiver tank on the bleed screw of the receiver (engine side).



5. Link the flexible of the brake bleeder on the purge screw of the command (cockpit side)



Closed position



6. Assure if the present tap on the flexible of the bleed tin is closed.

7. Fill in with 500ml of DOT4 brake liquid in the brake bleeder then closed it.

8. Pump for realize an under pressure of the bleeder at 25 PSI.



It's recommended for this step, to be 2 operators.

9. Unscrew slightly the bleed screw of the command (cockpit side) with a spanner 8 to allow the liquid to circulate.

10. **Place the brake bleeder lower that the input of the control receiver system (place the bleeder on the ground).**

11. Gradually open the valve on the bleeder and make sure there are no leaks.

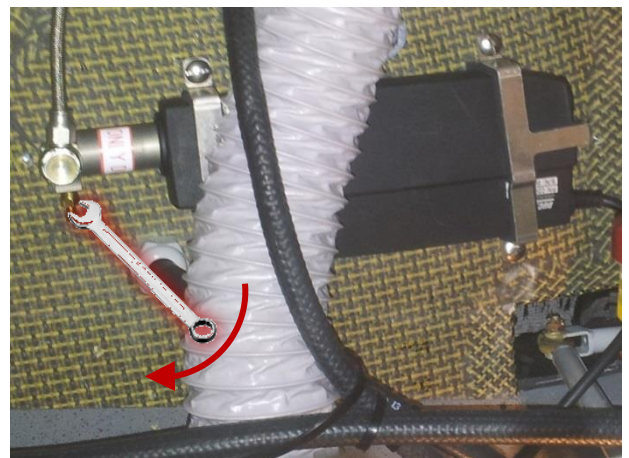

12. Then, unscrew slightly the bleed screw of the control receiver cylinder (engine side) with a spanner 8. Follow the progression of bubbles and of the DOT4 fluid in the tube of the receiver tank.

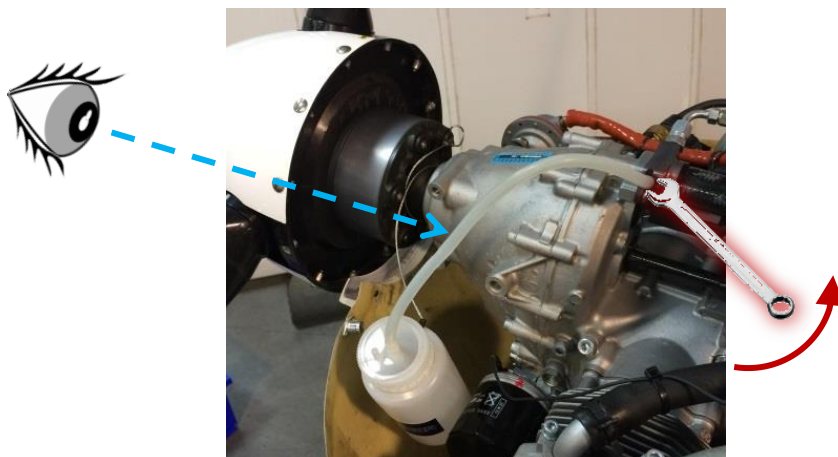

13. As soon as the fluid no longer seems to contain bubbles, close the bleed screw of the receiver (engine side). Wait for 5 to 10 seconds.
14. Then repeat the operation #12 and 13 for not having bubble present at the reopening of the bleed screw receiver cylinder (engine side).
15. Next, close the bleed screw of the command (cockpit side), and finally close the valve of the bleeder.
CAUTION, the bleeder is still under pressure.
16. Open the bleeder bottle cap to depressurize and replace the valve in open position.
17. Only now, you can remove the bleeder and the receiver tank from the installation.
You can then recover the liquid in your original container.



Do a checking of the system by operating the control.

Check the right displacement of the blades and the right consistency of the direction of rotation of the blades. In the case, the hydraulic pump, check the operating direction. If there is a reverse, that means the wire is reversed and you must change it.

In case of anomaly, return to the beginning with the command in output position.

If the problem continues, please to contact DUC Propellers Company.

If all of these operations are well applied, the hydraulic system is purged.

It is recommended to do the last checking of all the tightening of the hydraulic fittings:

- Bleed screws
- Hydraulic links
- Fixation screws of the command and the command receiver system

5.10. Finalization of propeller mounting

□ STEP 19.

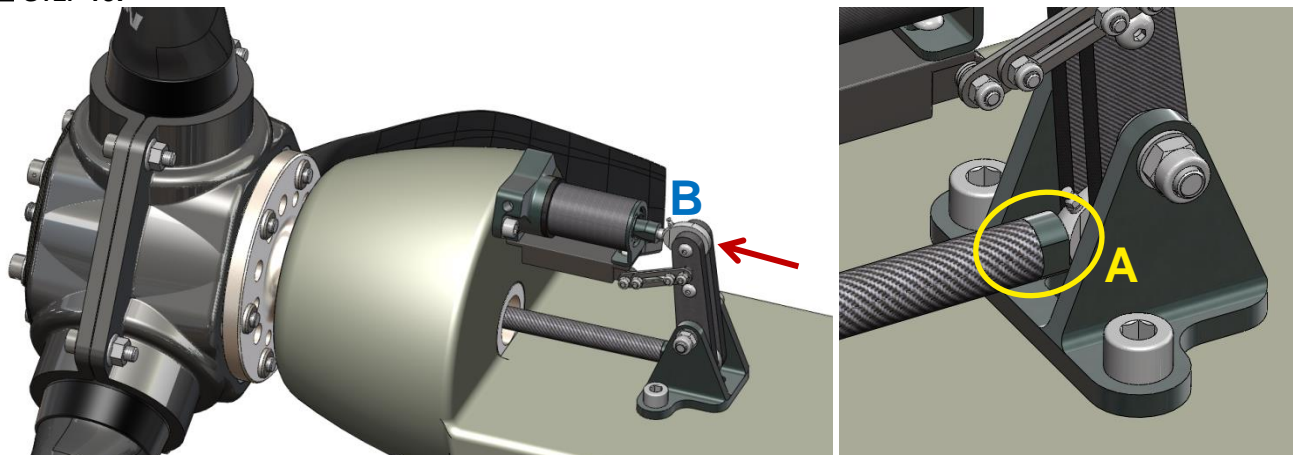

Check if the rod of the receiver cylinder rod is inside (B) and the carbon command tube is fitted with the lower ball joint (A).

Adjust the setting screw of the lower joint ball (A) to catch up the clearance between the tube and the ball joint. If necessary, use also the setting screw of the top ball joint (B) but prefer the lower ball joint (A).

Be careful, it's necessary to conserve a clearance of around 0.5mm because all of the materials expand during the engine warming.

When the setting is performed, **stop the screws with the locknut in A and B.** This setting is preliminary and will be adjusted during ground testing.

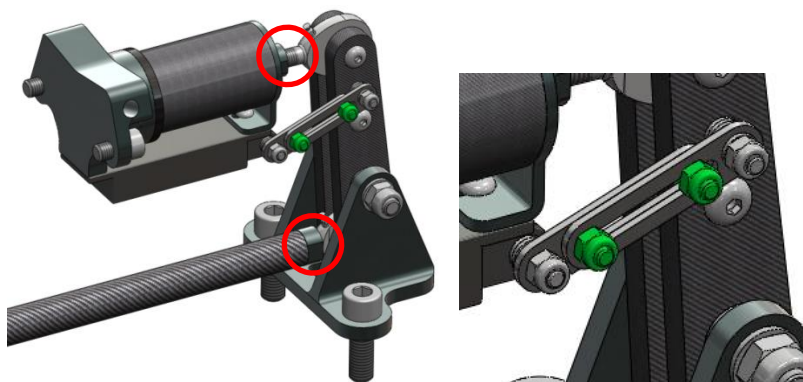

Be sure to keep the **screws sensors** of the link settings loosened to allow mobility.

At this point, the propeller is assembled, tightened, purged but not settled neither secure.

PRECAUTIONS

If you notice any abnormal installation or operation, do not undertake the flight and immediately contact DUC Propellers Company.



Being aware of potential risks during assembly and initial testing of the propeller. Stay focused, attentive and vigilant to your environment. Recheck several times points to be observed. Maintaining high safety clearance during the set operation.

The products of the DUC Propellers Company must be installed and used according to the instruction manuals provided. No modification can be made without the agreement of DUC Propellers Company. The non-compliance of these data assumes no responsibility for the DUC Propellers Company and makes out the warranty of the considered products (See section 6. **General terms of sale**).

6. Setting the small pitch stop and and static tests on ground of the propeller



RECOMMENDATION

As recommended by the BRP manufacturer of Rotax engine, it's strongly recommended to use variable pitch **FLASHBLACK** & **SWIRLBLACK-3** propeller with an aircraft equipped with a vacuum indicator on engine intake manifold (**Pressure of the engine intake - MAP**) to know the engine load. Refer to your engine manual or the section **12.3 Moment of inertia** of the propeller

Propeller Type					
FLASHBLACK		FLASHBLACK-2		SWIRLBLACK-3	
Diametre (mm)	Inertia (kg.cm ²)	Diametre (mm)	Inertia (kg.cm ²)	Diametre (mm)	Inertia (kg.cm ²)
1620	3811	1620	4192	1620	3630
1660	3954	1660	4349	1660	3765
1700	4104	1700	4514	1700	3908
1730	4208	1730	4629	1730	4008
1750	4280	1750	4708	1750	4076
1850	4643	1850	5107	1850	4422
1900	4823	1900	5306	1900	4594

Engine performance data's.

The preliminary tests are important

1) Tight the small-pitch stop (**M10 nut**) to let **a clearance of 1mm** with the carbon washer.

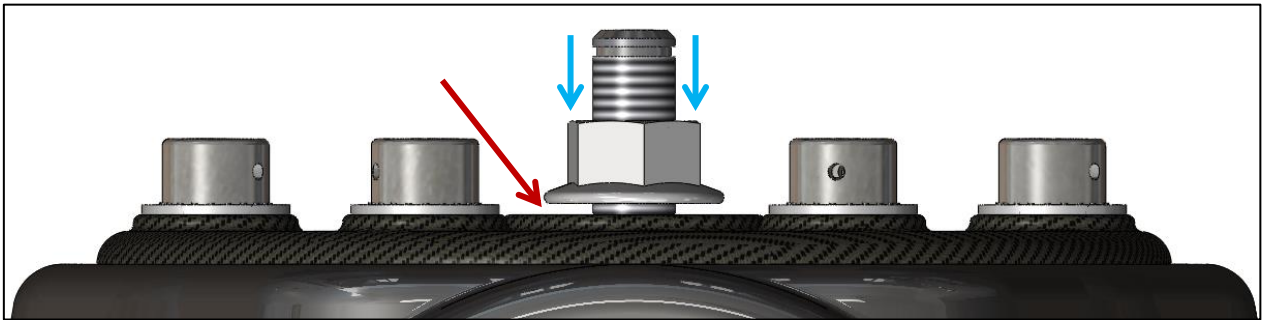

2) Check that the control is still in position small-pitch.

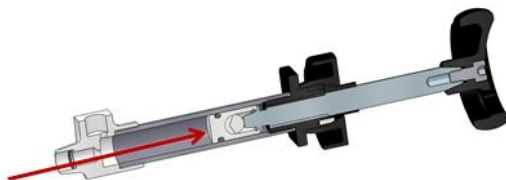

3) Brake applied, start the engine and warm it as recommended by the manufacturer. The aim of this ground test is to set the propeller, at full throttle, at 5700-5800 rpm.

4) When the motor is in operational condition, do the following operation:

A. Increase the throttle smoothly to reach 5500±200 rpm.



B. Acting on the pitch command to increase the pitch and adjust in parallel the position of the throttle to keep a stable engine speed at 5500 ± 200 rpm.

Make this operation to reach the fully depressed position of the throttle.

Reminder to increase the pitch:

WHEEL: Tight the wheel

LEVER: Push the level (opposite according to the direction of installation)

CONSTANT SPEED BOX: In Manual mode, increase the pitch by pressing down the switch.

C. At full throttle, gently reduce the pitch to reach the engine speed of 5800 ± 20 rpm.

5) When this setting is achieved, **DO NOT TOUCHE ANYMORE THE PITCH COMMANDE.**

6) Reduce throttle, shut down the engine and secure environment to perform an action on the propeller.

7) Set the small-pitch stop as the **M10 nut press slightly a contact on the carbon washer.**

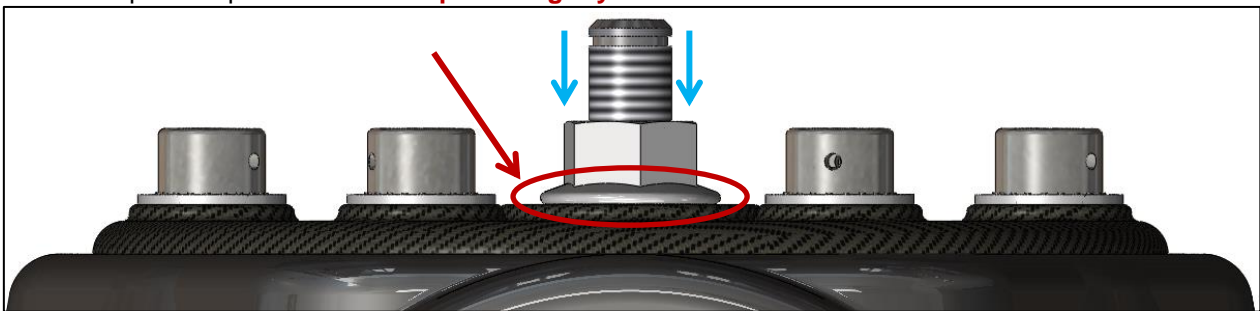

8) Replace the pitch controller in small-pitch position to reduce the pitch to the maximum.

9) Manually push to the maximum the top of the control receiver system:

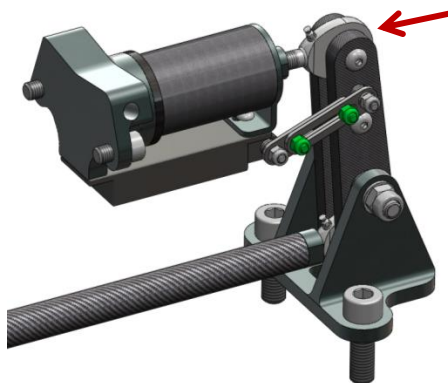

10) Set once again the lower ball A to remove the clearance in the carbon tube. If the ball A is not enough, uses the setting screw of the ball B. **Keep an estimated clearance of 0.2mm** in the mobility of the tube.

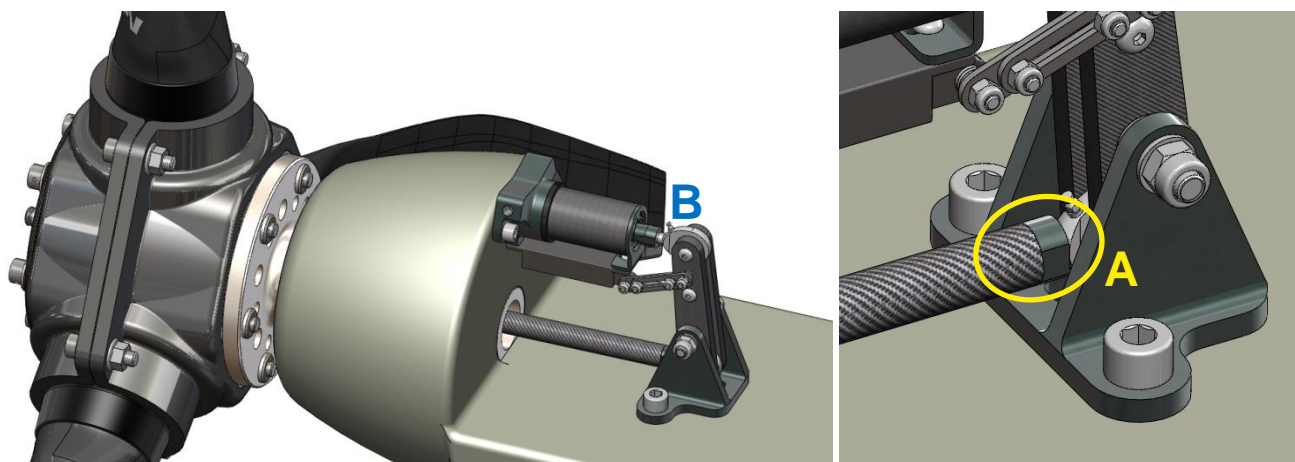

- 11) Then adjust the rods of the position sensor on the receiver control system:
- Retract the shaft position sensor to obtain only the first LED on
 - Adjusting the position of the adjustable rods.
 - Tighten the cap screws of these rods.

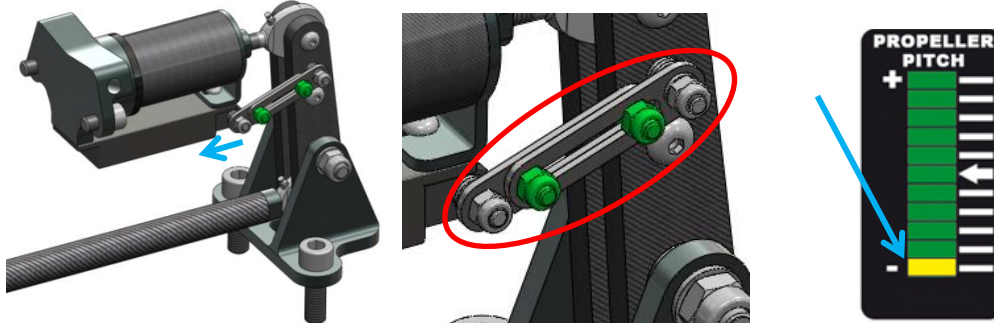

- 12) Finalize the static tests with a new test, engine on, by varying the engine speed and propeller pitch. For the Constant Speed box, do the specified function test specified in the FLYBOX manual.

- 13) When everything is set, set up the **safety wire Ø0.8mm (Ø0.03")** over the screw heads for safe installation.



- 10) After a final check (position and orientation of parts, tightening, ...), install the spinner on the spinner mounting plate by **tightening the screws to a torque of 4 Nm (0.4kg / m)** with the appropriate tools.

When the presence of a mark, be sure to follow the indexing of the spinner from the plate.

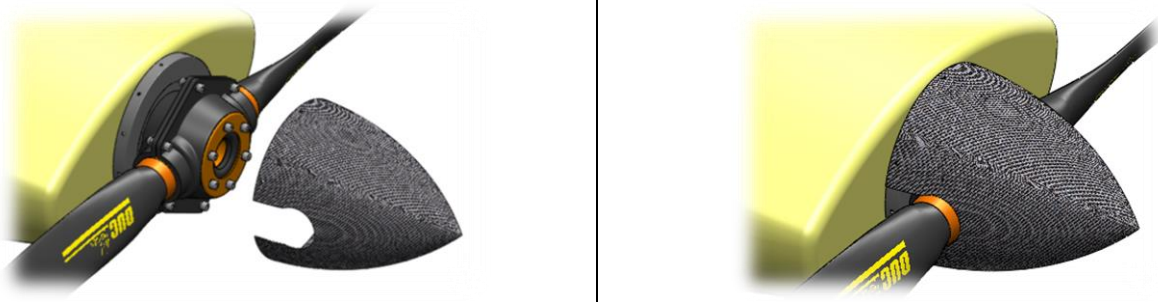

At this point, the small-pitch stop of your FLASHBLACK/-2 or SWIRLBLACK-3 propeller is set for the first taxi tests and then fly tests).

The user must perform the appropriate regulations procedures to change the propeller in accordance with applicable regulations of the aircraft.

7. First taxi tests and then fly tests of the propeller

During the Vital Action (A-C-H-E-V-E-R) before each flight, it is recommended to check the proper functioning of the pitch variation of the propeller.

Before the first flights, do a run-up to get 5600-5700 rpm. If not, change the setting of the small-pitch stop.

During take-off or landing, it is imperative to return the propeller to small-pitch.

In flight, changing the pitch angle by continuously monitoring the Manifold Pressure (MAP).



RECOMMENDATION

As recommended by the BRP manufacturer of Rotax engine, it's strongly recommended to use variable pitch **FLASHBLACK** & **SWIRLBLACK-3** propeller with an aircraft equipped with a vacuum indicator on engine intake manifold (**Pressure of the engine intake - MAP**) to know the engine load. Refer to your engine manual or the section **12.3 Moment of inertia** of the propeller

Propeller Type					
FLASHBLACK		FLASHBLACK-2		SWIRLBLACK-3	
Diametre (mm)	Inertia (kg.cm ²)	Diametre (mm)	Inertia (kg.cm ²)	Diametre (mm)	Inertia (kg.cm ²)
1620	3811	1620	4192	1620	3630
1660	3954	1660	4349	1660	3765
1700	4104	1700	4514	1700	3908
1730	4208	1730	4629	1730	4008
1750	4280	1750	4708	1750	4076
1850	4643	1850	5107	1850	4422
1900	4823	1900	5306	1900	4594

Engine performance data's.

8. Management of the failure of the variable pitch system



In the unlikely event of hydraulic failure, the propeller comes naturally in small-pitch stop thanks to the return spring.

In case of power failure to the versions using the hydraulic pump, the cylinder of pump remains in position, thus the pitch angle of the blades remains in position.

9. Installation without spinner or with spinner other than DUC



In the case of installation of the propeller **without spinner mounting plate** or **other spinner mounting plate**, be careful to check the following points:

- ✓ **Length of the fixing screws of the propeller:** Must be adapted according to the thickness of the spinner mounting plate.
- ✓ **Mechanical resistance of the plate when tightening:** For a similar assembly of the DUC spinner, the plate takes the tightening of the propeller fixing screws. It is, therefore, necessary to ensure that the used plate can withstand the clamping and resist of the propeller operate efforts (crushing of the plate).

IMPORTANT

The spinner is an important element for engine cooling.

The aircraft must not fly without propeller spinner. Mounting a different cone will be an amendment to this instruction manual approved by the DUC in order to confirm its compatibility mounting the propeller.

WARRANTY CONDITIONS

The user is still flying under its full responsibility (see section **6. General terms of sale**).

10. Potential use & Propeller maintenance

10.1. The potential use of the propeller: **Unlimited**

The propellers DUC have an unlimited flight potential in normal operation conditions.

To keep the unlimited potential, DUC Propellers Company has defined a TBO (Time Between Overhaul) for a propeller depending on its engine.

This TBO according to the engine is indicated in this manual (see **2. Applications**). **For ROTAX engine TBO is set at 1500 flight hours.** In all cases, it may not exceed 5 years.

To achieve this, the propeller must be returned to the DUC Propellers Company to perform a full control, verify its proper use and change the wearing parts if necessary.

Following this inspection and maintenance of the propeller, the propeller is credited again with the same TBO and is returned to you.

The cost of maintenance when you reach 1500 hours of flight on Rotax is 800 € excl. tax, in other words, 0.54€ per hour of flight. The deliveries costs of sending and returning will be payable by the customer.

Remember, there is no imperative of logbook in light aviation. But know that this control is highly recommended for the continuing airworthiness and safety.

10.2. Propeller maintenance schedule

Type	Actor	Frequency
Regular	User	Each pre-flight
General	the user or an aeronautics workshop	Every 100 hours or annually
Complete	DUC Propellers Company	Each TBO

10.3. Regular maintenance (by the user)

For a safety use of the FLASH propellers, it is necessary that the user performs regular maintenance to detect any abnormalities. This maintenance is usually just a simple check.

The frequency of checking: Each pre-flight

Control methods: Visual inspection & Manual handling

Checkpoints:

- Fixation of the propeller: Manually maintaining the tip of a blade of the propeller, shake it firmly to feel if a too much clearance appears in the setting of the propeller.
- Degradation of material: Check visually the entire propeller without dismantling (blade root, Inconel leading edge, the surface of the blade, spinner, hub, etc.)
- Fixation of the spinner: Check visually the fixation screws of the spinner. A marking paint can be made between each screw and spinner to have a means of visual inspection of proper tightening the screws.

Possible problems:

- Too much clearance in the propeller fixation
- Surface degradation due to dirt or impact / Crack apparent

Corrective actions (depending on the importance):

1. Clean the propeller with the DUC cleaning treatment DUC (ref. 01-80-003)
2. Perform a repair with the DUC repair kit (ref. 01-80-004)
3. Tighten the screws to proper torque with a wrench
4. Replace(s) damage component(s)
5. Contact DUC Propellers Company to define a solution

10.4. General maintenance (by the user or an aeronautics workshop)

A general maintenance by the user or an aeronautics workshop must be made at a lower frequency.

The frequency of checking: Every 100 hours or annually

Control methods: Visual inspection & Torque wrench

Checkpoints:

Fixation of the propeller: By removing the spinner of the propeller, check the proper tightening of the screws to the wrench. These screws of the hub should be tightened to proper torque, defined in the installation instructions attached.

A marking paint of all the screw/washer/hub after tightening can be done to help make a visual check outside of the general maintenance.

- Degradation of material: Check visually the entire propeller (blade root, Inconel leading edge, the surface of the blade, spinner, hub, etc.)

Possible problems:

- Too much clearance in the propeller fixation
- Surface degradation due to dirt or impact / Crack apparent

Corrective actions (depending on the importance):

1. Clean the propeller with the DUC cleaning treatment DUC (ref. 01-80-003)
2. Perform a repair with the DUC repair kit (ref. 01-80-004)
3. Tighten the screws to proper torque with a wrench
4. Replace(s) damage component(s)
5. Contact DUC Propellers Company to define a solution

10.5. Complete maintenance (by DUC Propellers Company)

Upon reaching the TBO (potential flight time between overhaul) defined by DUC Propellers Company, the propeller must be returned to the corporation for a full inspection of all components of the propeller.

See section 2. **Applications** for the potential value of an hour's flight engine.

The possible degradation of the propeller components may vary depending on the location of use.

11. General terms sale

11.1. Ordering procedure

Orders placed by fax, by phone or mail server engage the customer upon receipt by our Customer Service Order and the Regulations.

11.2. Delivery

DUC Propellers Company agrees to make every effort to deliver the order within the shortest time, and the receipt of the order together with the Regulation. The delivery times indicated on the order are only indicative and the possible delays do not entitle the buyer to cancel the sale, to refuse the goods or claim damages. Any claim for non-compliance or failure will be sent within one week following the date of receipt of order.

The DUC Propellers Company is released from its obligation to deliver for all fortuitous events or force majeure. As an indication, the total or partial strikes, floods, fires are cases of force majeure. The transfer of ownership of goods supplied or delivered is suspended until full payment of the price by the customer and without affecting the transfer of risk.

11.3. Price

The DUC Propellers Company may change its prices at any time.

The customer agrees to pay the purchase price in effect at the time of order entry. Regulation Order is payable in advance in one payment when sending the DUC Propellers Company purchase order.

11.4. Right of withdrawal

Under Article L121-16 of the Consumer Code, the customer shall have seven clear days after the delivery of his order to return the products to the DUC Propellers Company for exchange or refund, without penalties except for the return costs. Returned products must not have suffered modification, damage consequence of shock or improper use and be packaged in original packaging. Goods shipped with postage due will not be accepted.

11.5. Warranties

The DUC Propellers Company's products must be installed and used in accordance with instruction manuals provided. No changes can be made without the prior approval of the DUC Propellers Company. The failure of these data releases any liability of the DUC Propellers Company and makes non-warranty the considered products.

The user is still flying under its sole responsibility.

The legal guarantee of industrial products is six months or for the potential duration of the helix (depends on which engine it is installed) against defects and hidden defects. See the section **2. Applications** to determine the potential value of an hour's flight engine.

DUC Propellers Company guarantees its product defect under normal use in the manner described below: If the customer finds a defect, he must report it immediately to the DUC Propellers Company and features of one month after its purchase to return to Company DUC Helices, all structural defects will snuff into account (except for damage result of incorrect operation, shock, injury, impairment or neglect, water or generally inappropriate use by the engine type, power, speed, and gear). To qualify for this warranty, the customer must send at its expense within one month after its purchase to be returned to Company with DUC Propellers Company delivery order attached to the product. In return, the DUC Propellers Company takes no responsibility for damage or loss during transit due to improper or inadequate packaging. The Company DUC Propellers Company then returned at his expense to the customer at the address on the delivery note, an identical or equivalent.

In addition to these guarantees, the Company DUC Propellers Company provides no other warranties.

11.6. Privacy Policy

All the data you entrust to us are able to process your orders. Under Law No. 78-17 of January 6, 1978, relating to data, files and freedoms you have with the customer service Company DUC Propellers Company right to access, review, correct, correct and delete data you have provided.

11.7. Litigation

Any order placed convincing the customer, without any restriction, the General Conditions of the sale of the DUC Propellers Company. Any dispute concerning the sale (price, GTS, product ...) will be subject to French law before the Tribunal de Commerce de Lyon.

12. Annexes

12.1. The dimension of the ROTAX 912/912S/914 propeller-shaft

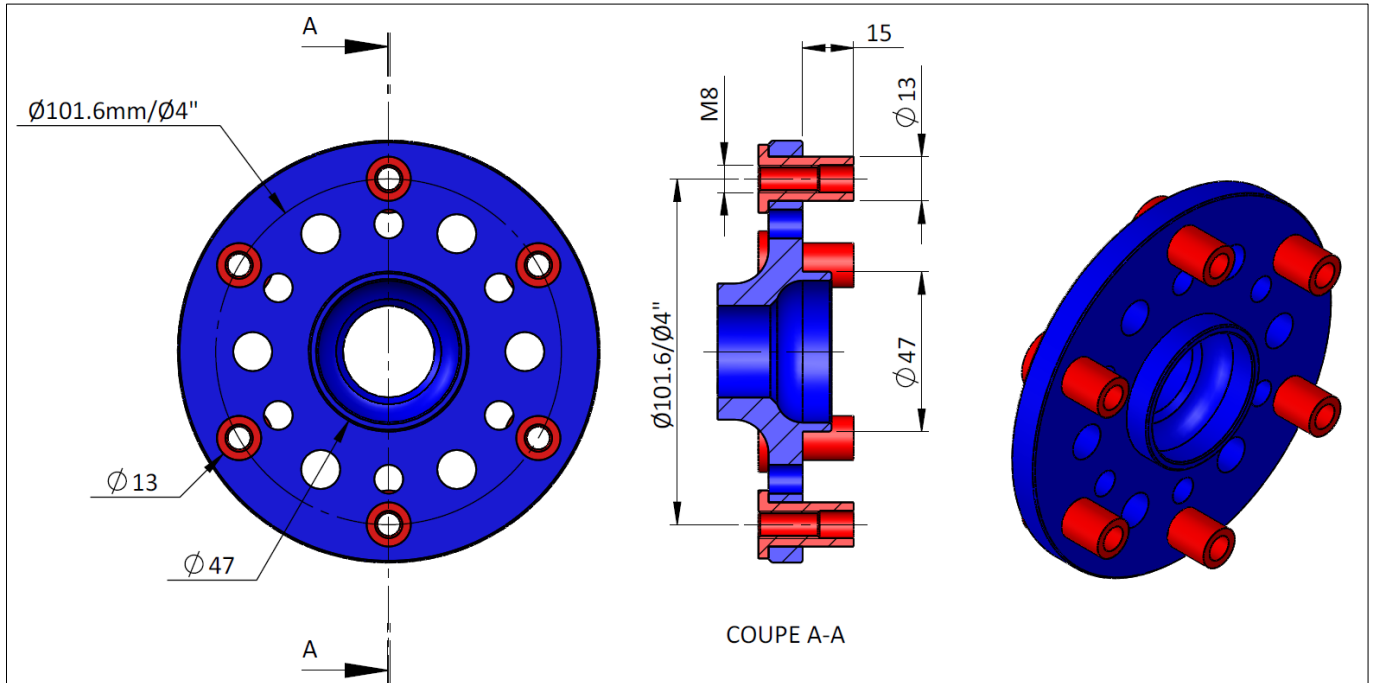

12.2. Airfoil

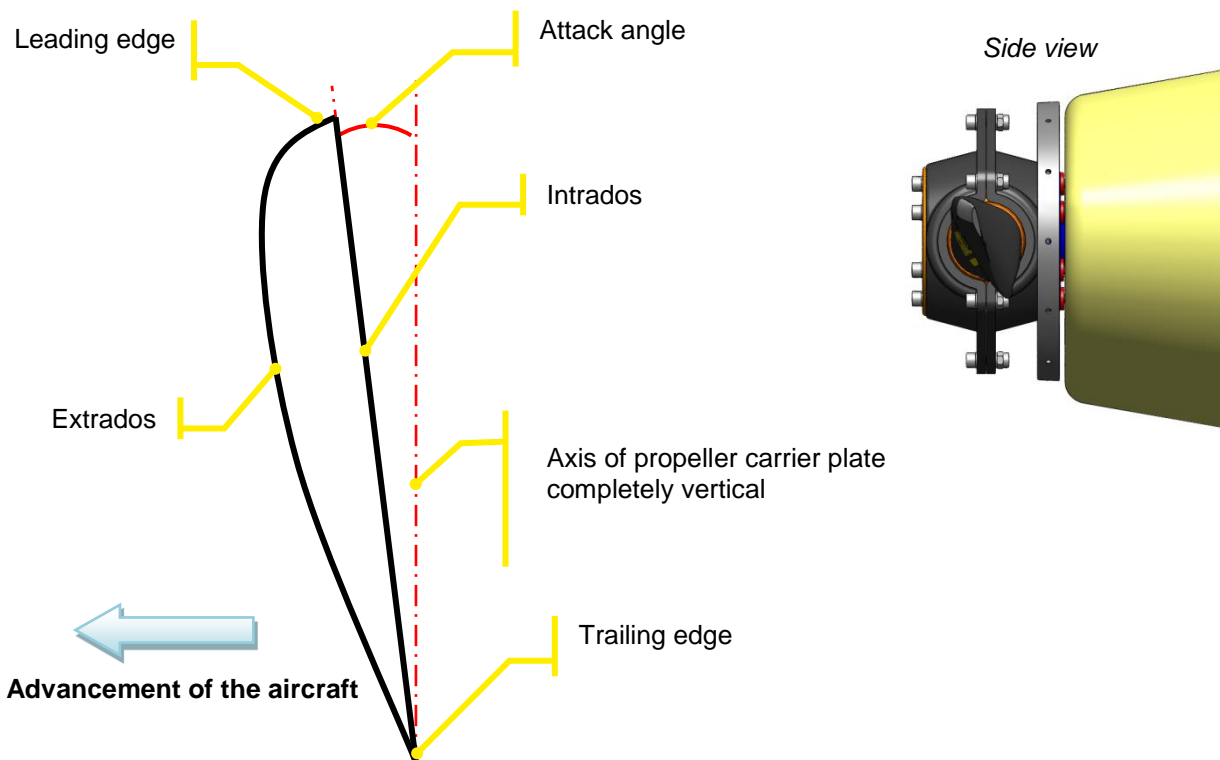

12.3. Moment of inertia of the propeller

Propeller Type					
FLASHBLACK		FLASHBLACK-2		SWIRLBLACK-3	
Diametre (mm)	Inertia (kg.cm ²)	Diametre (mm)	Inertia (kg.cm ²)	Diametre (mm)	Inertia (kg.cm ²)
1620	3811	1620	4192	1620	3630
1660	3954	1660	4349	1660	3765
1700	4104	1700	4514	1700	3908
1730	4208	1730	4629	1730	4008
1750	4280	1750	4708	1750	4076
1850	4643	1850	5107	1850	4422
1900	4823	1900	5306	1900	4594

12.4. Engine performance data's

✂

PERFORMANCE DATA – ROTAX 912 (80hp)				
Step	Engine rpm	Power HP	Torque Nm	MAP in.HG
Take-off 5 min max	5800	80	98.1	Full power
Cruise	5500	78	100.7	Full power
75 %	5000	58	83.1	27.2
65 %	4800	50	75	26.5
55 %	4300	43	70.8	26.3

✂

PERFORMANCE DATAS – ROTAX 912S (100hp)				
Step	Engine rpm	Power HP	Torque Nm	MAP in.HG
Take-off 5 min max	5800	100	121.0	27.5
Cruise	5500	90	119.8	27
75 %	5000	68	97.4	26
65 %	4800	60	88.7	26
55 %	4300	50	84.3	24

✂

PERFORMANCE DATAS – ROTAX 914 (115hp)				
Step	Engine rpm	Power HP	Torque Nm	MAP in.HG
Take-off 5 min max	5800	115	139	39
Cruise	5500	100	128	35
75 %	5000	74	105	31
65 %	4800	64	95	29
55 %	4300	54	90	28





12.5. Operating limitation of the FLASH propeller

Designation	Maximum engine power	Maximum rotational speed
Two-blade Inconel FLASHBLACK propeller, Right	120 hp	2800 rpm
Three-blade Inconel FLASHBLACK propeller, Right	120 hp	2800 rpm
Three-blade Inconel SWIRLBLACK-3 propeller, Right	120 hp	2800 rpm
Three-blade Inconel FLASHBLACK-2 propeller, Left	120 hp	2800 rpm

12.6. Identification marking of the propeller

12.6.1. Manufacturing label

As the propeller is dismountable, each component (blade and half-hub) has a manufacturing traceability label which identifies the component and specifies its own serial number:

FLASH-PV Right Blade	FLASH-2-PV Left Balde	SWIRL-3-PV Right Blade	Half-hub FLASH (2-blade / 3-blade)
			

12.6.2. Propeller label (for LSA certified version)

At the end of the manufacturing, a 2nd label - the propeller label - is placed on each component of the propeller (blade and half-hub) with the following information:

1st line: Part number of the propeller model

Two-blade (2) or Three-blade (3)

Left (G) or Right (D)

Reinforced structure (R) and/or Inconel leading edge (I)

Diameter in mm

2nd line: Propeller data

Serial number of the propeller (not only the component)

Value of the static balancing of each blade of the prop

P/N: H-FSH_3-D-R_I-1730

S/N: XXXX EQ-003: XX

12.7. Calculation of the centrifugal force of the FLASH Inconel blade

Details on request.

12.8. Centrifugal force test

Details on request.

12.9. Breaking test of the 2-blade Inconel FLASH propeller

Details on request.

12.10. Declaration of conformance of the FLASH propellers

12.10.1. Design and Construction

The propellers were designed to be adapted to the applications described in section 2. Every designs features are reliable and mastered by DUC Hélices company.

The materials used in the propeller were selected for their technical properties to be conforms to the definition of the propeller and durable during the propeller life.

About the ground adjustable system, the design allows a fine and careful setting of the propeller blade pitch. Also, the system is robust to not change during normal and emergency operation of the propeller and also after many settings.

Definition propeller conforms to withstand the stresses of operation on all its lifetime.

12.10.2. Tests and Inspections

The propeller completes the tests and inspections described below, without failure or malfunction.

Strength Testing:

Proof of strength is presented in section 12.8. Centrifugal force test. This test was done in a static pull test.

Endurance Testing:

The propeller conforms to endurance test of each application exposed in section 2.

Teardown Inspection:

After completion of each test described above, the tested propeller was completely disassembled and each propeller parts were inspected. No failure or crack was found.

Propeller Adjustments and Parts Replacements:

During the tests and inspections carried out, no parts have to be repaired or replaced. All propeller parts resisted the tests and were conform after inspections.

12.10.3. Design Control

The propeller was design on CAD software. All the CAD files and 2D drawings are stored in the Design Office of DUC Hélices Company, as the definition of the FLASH configurations. All the technical data (dimensions, materials and processes) are saved in manufacturing procedure. Also, a copy all these data are archived out of the company.

12.10.4. Quality Assurance

DUC Hélices Company is ISO 9001:2015 certified for its management of the quality system, which ensures manufactured propellers maintain conformity to the established design. Refer to page 2.

12.10.5. Certification of Conformity for ASTM F2506-13

“ASTM F2506-13 is the standard specification for design and testing of fixed-pitch or ground adjustable for Light Sport Aircraft propellers.

DUC Hélices Company declares that the propeller complies with the ASTM F2506-13 standard and after verification, it responds every requirement.”

M. Vincent Duqueine
Manager
24/02/2021

DUC Hélices Propellers
contact@duc-helices.com · www.duc-helices.com
Aérodrome de Villefranche-Tarare
69620 FRONTENAS - FRANCE
Tél. : +33 (0)4 74 72 12 69
SIRET : 413 269 887 00035

DUC Hélices Propellers

Aérodrome de Villefranche-Tarare (LFHV)
289 Avenue Odette & Edouard DURAND
69620 FRONTENAS - FRANCE
Phone. : + 33 (0)4 74 72 12 69 - Fax : +33 (0)4 74 72 10 01
E-mail : contact@duc-helices.com - www.duc-helices.com
After sales services : service.technique@duc-helices.com



ISO 9001:2015
Certified Company

INFO
PILOT



Protect your propeller!

Neoprene cover – Commercial reference: O1-80-002

INFO
PILOT



Save money!

Degrease your propeller

REDUCE CONSUMPTION

by improving performance

Commercial reference: O1-80-003

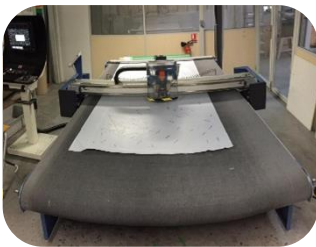

Data and pictures included in this instruction manual are exclusively property of DUC Hélices Company. Any part of this manual can be reproduced or transmitted in any form with any means, electronic or manual, for any reason, without written approval of DUC Hélices Company.